

Setup Sheet



Editable by
Am0 at PetitRC.com

Driver _____

Track / City _____

Event _____ Date ____ / ____ / ____

Conditions

- | | | | | |
|--|---------------------------------|------------------------------------|---------------------------------------|---------------------------------------|
| <input type="checkbox"/> High traction | <input type="checkbox"/> Smooth | <input type="checkbox"/> Bumpy | <input type="checkbox"/> Low traction | <input type="checkbox"/> Med traction |
| <input type="checkbox"/> Clay | <input type="checkbox"/> Sandy | <input type="checkbox"/> Soft dirt | <input type="checkbox"/> Grass | <input type="checkbox"/> Hard soil |
| | <input type="checkbox"/> Wet | <input type="checkbox"/> Dry | <input type="checkbox"/> Dusty | <input type="checkbox"/> Other |

Front Suspension

Shock Mounting & Camber link

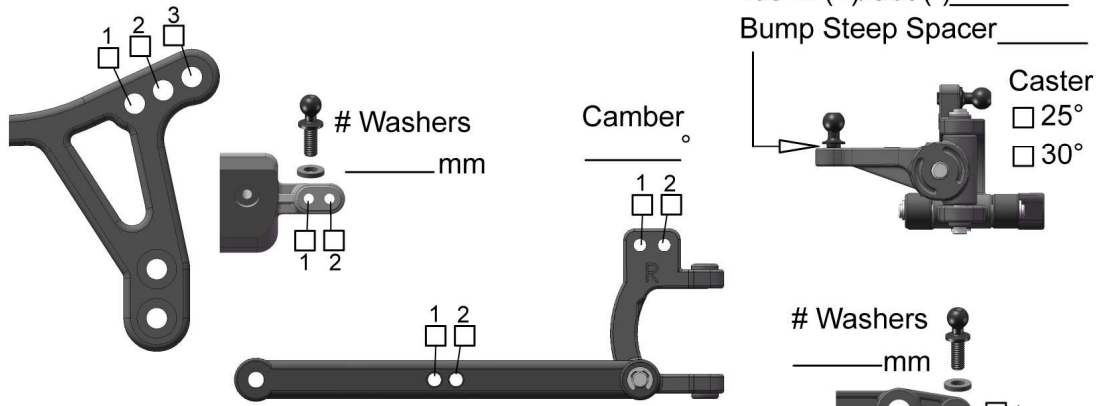

Ride height _____

Toe-in (+)/Out (-) _____ °
Bump Steep Spacer _____

Caster
 25°
 30°

Washers
_____ mm
 1
 2

Front Shocks

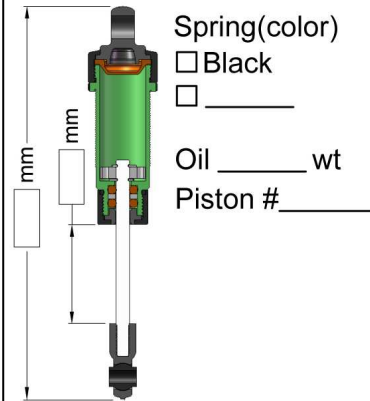

Spring(color)
 Black

Oil _____ wt
Piston # _____

Rear Suspension

Shock Mounting & Camber link

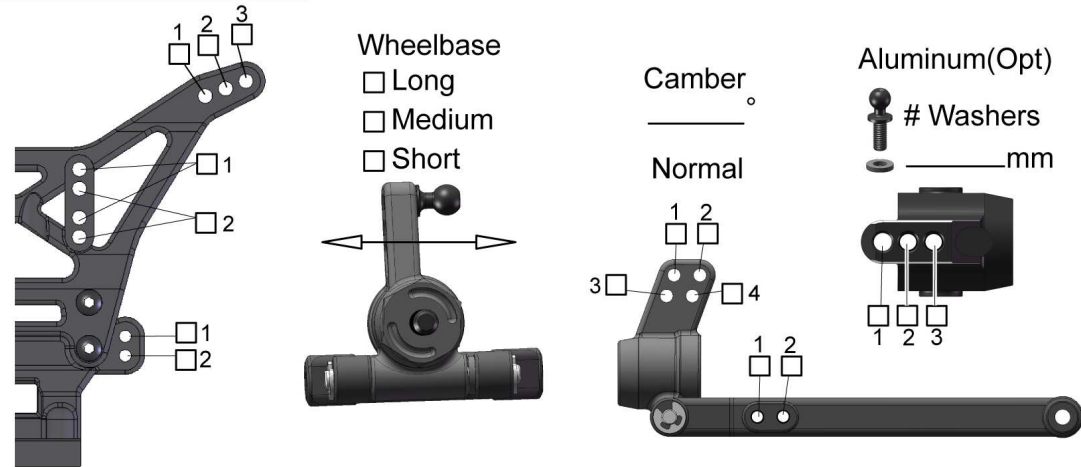

Ride height _____

Wheelbase
 Long
 Medium
 Short

Camber

Normal

Aluminum(Opt)
Washers
_____ mm
 1
 2
 3

Rear Shocks

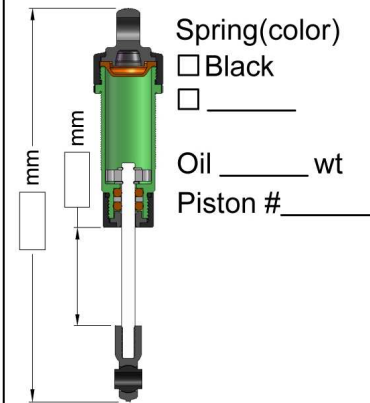

Spring(color)
 Black

Oil _____ wt
Piston # _____

Front Tires & Wheels

Front Tires _____
Inserts _____ Wheels _____

Rear Tires & Wheels

Rear Tires _____
Inserts _____ Wheels _____

Batteries

Servo _____
Esc _____
Batteries _____

Motor

Motor _____
Pinion/Spur _____ / _____

Other

Wing _____
Wing Angle 4° 10°

Comments

Notes _____
