

T2 EVO

SETUP SHEET for the TeamC T2 EVO

Editable by Arn0 at PetitRC.com

Driver Zacarias Villalba

Track / City Starting setup for dirt low-medium traction tracks

Event _____ Date 21 / 02 / 2013

Conditions

- | | | | |
|--|---|--|--|
| <input checked="" type="checkbox"/> Smooth | <input checked="" type="checkbox"/> Bumpy | <input checked="" type="checkbox"/> Low traction | <input checked="" type="checkbox"/> Med traction |
| <input type="checkbox"/> High traction | <input type="checkbox"/> Sandy | <input type="checkbox"/> Grass | <input type="checkbox"/> Hard soil |
| <input checked="" type="checkbox"/> Clay | <input type="checkbox"/> Wet | <input type="checkbox"/> Dusty | <input checked="" type="checkbox"/> Other |
| | <input checked="" type="checkbox"/> Soft dirt | | |
| | <input type="checkbox"/> Dry | | |

Front Suspension

Shock Mounting&Camber link

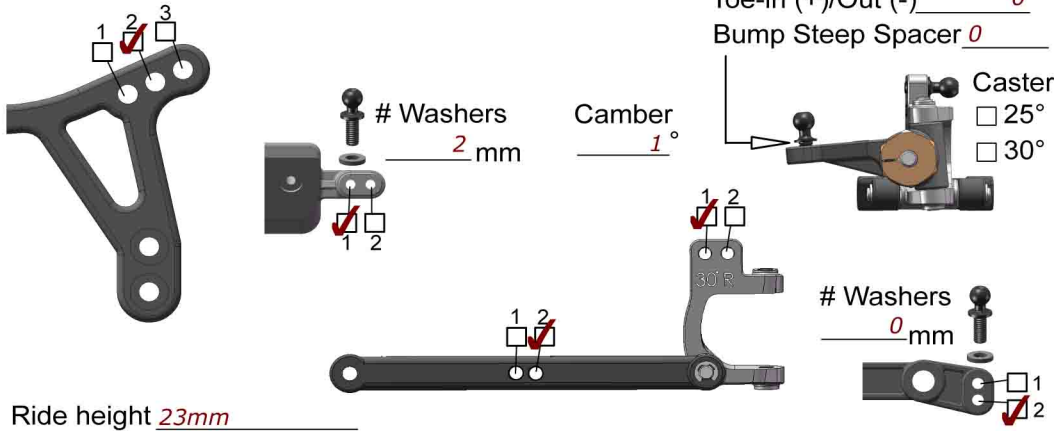

Front Shocks



Rear Suspension

Shock Mounting&Camber link

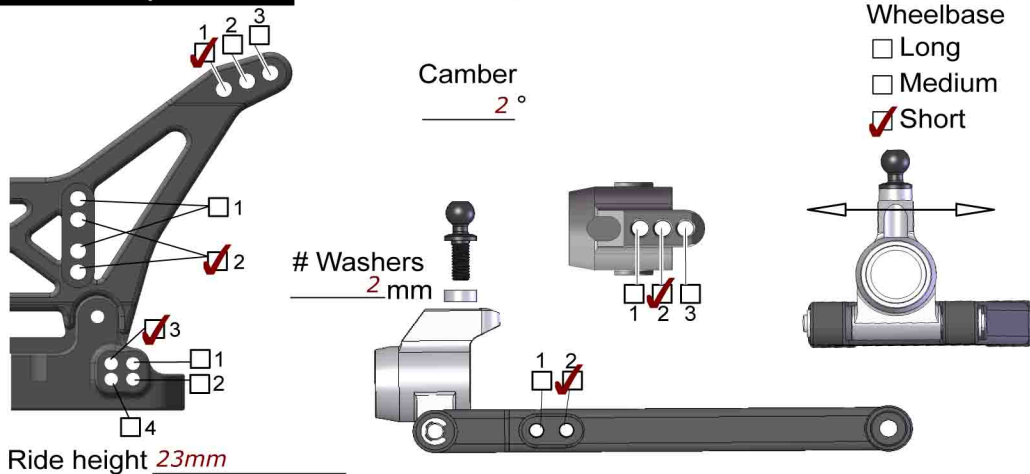

Rear Shocks



Diff

Brand n/a
 Oil wt Lubricant oil

Front Tires&Wheels

Front Tires Proline Bow-Tie, JConcepts DD
 Inserts Std Wheels Std

Front Tires&Wheels

Front Tires JConcepts Groovy
 Inserts Std Wheels Std

Batteries

Servo Futaba
 Esc Speed Passion GT2.0
 Batteries Intellect 5600mha

Motor

Motor Speed Passion
 Pinion/Spur 81 / 25

Other

Wing Std
 Wing Angle 4° 10°

Comments

Notes _____

Polished gear diff with lubricant oil or grease. Battery back position, 30° aluminum caster block, graphite rear shock tower, aluminum rear pivot, brass 30 g front bulkhead, nylon Idlegear, aluminum servo mount, aluminum rear hub, aluminum motor mount, aluminum rear brace mount H.