

# TC02

SETUP SHEET for the  
TeamC TC02

Editable by  
Arn0 at PetitRC.com



Driver \_\_\_\_\_

Track / City \_\_\_\_\_

Event \_\_\_\_\_ Date \_\_\_\_ / \_\_\_\_ / \_\_\_\_

## Conditions

- |  |                                 |                                    |                                       |                                       |
|--|---------------------------------|------------------------------------|---------------------------------------|---------------------------------------|
| <input type="checkbox"/> High traction | <input type="checkbox"/> Smooth | <input type="checkbox"/> Bumpy     | <input type="checkbox"/> Low traction | <input type="checkbox"/> Med traction |
| <input type="checkbox"/> Clay          | <input type="checkbox"/> Sandy  | <input type="checkbox"/> Soft dirt | <input type="checkbox"/> Grass        | <input type="checkbox"/> Hard soil    |
|  | <input type="checkbox"/> Wet    | <input type="checkbox"/> Dry       | <input type="checkbox"/> Dusty        | <input type="checkbox"/> Other        |

## Front Suspension

### Shock Mounting&Camber link

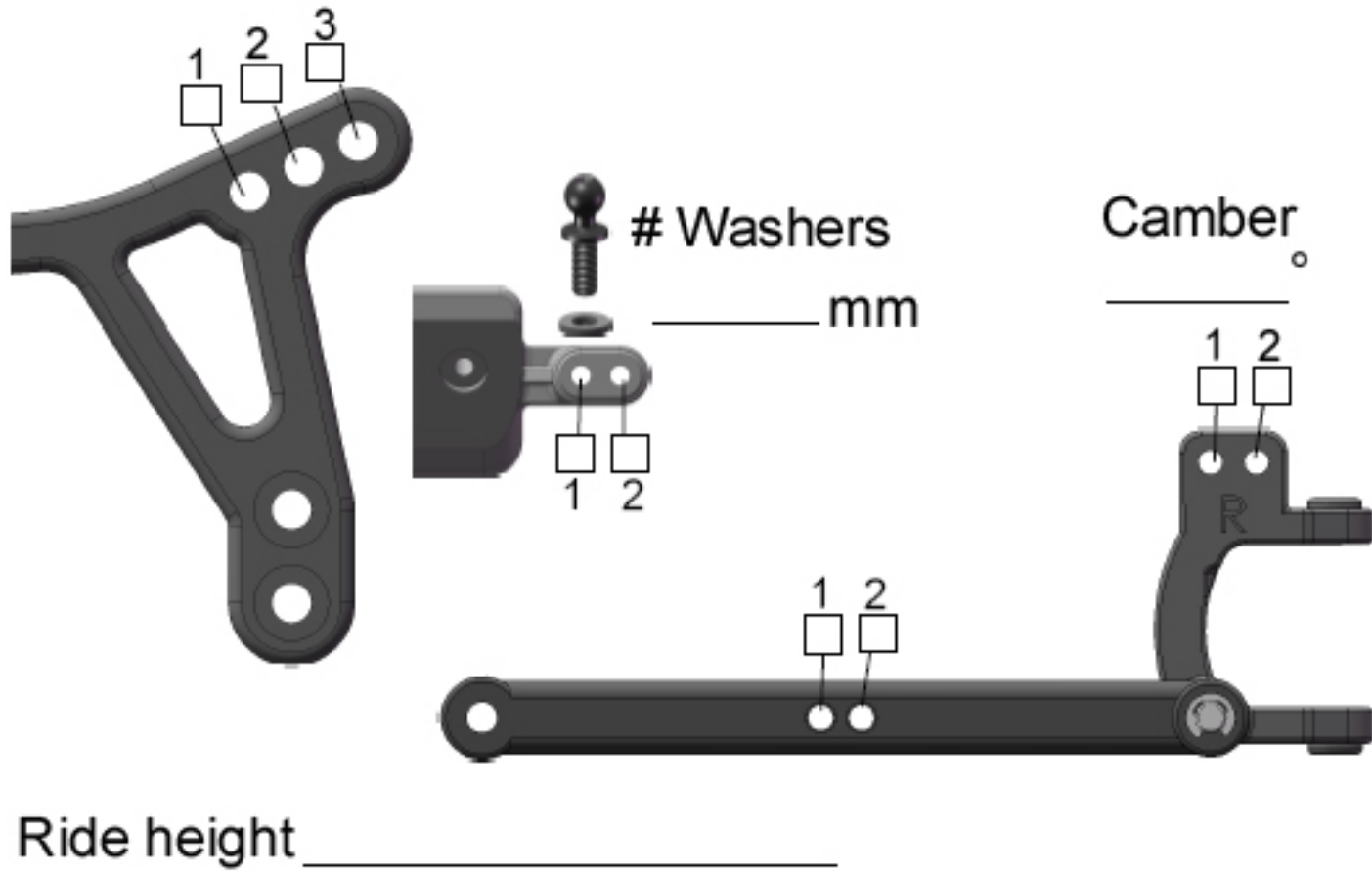

Toe-in (+)/Out (-) \_\_\_\_\_ °  
Bump Steep Spacer \_\_\_\_\_

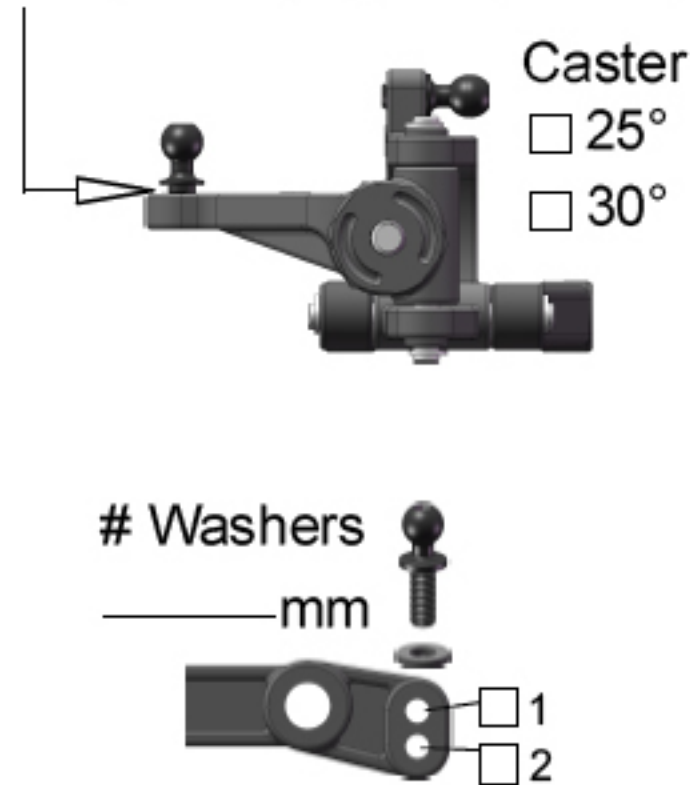

## Front Shocks

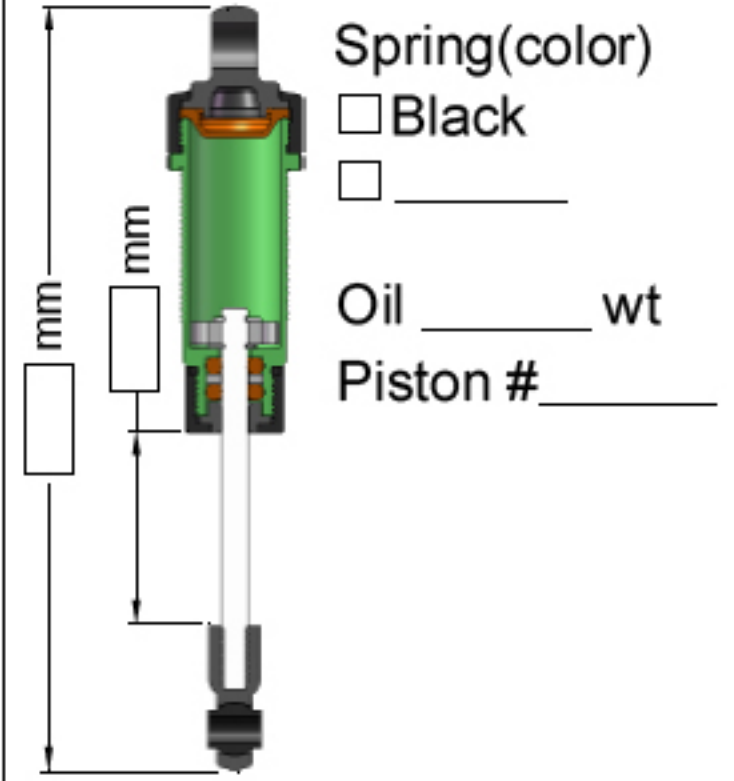

## Rear Suspension

### Shock Mounting&Camber link

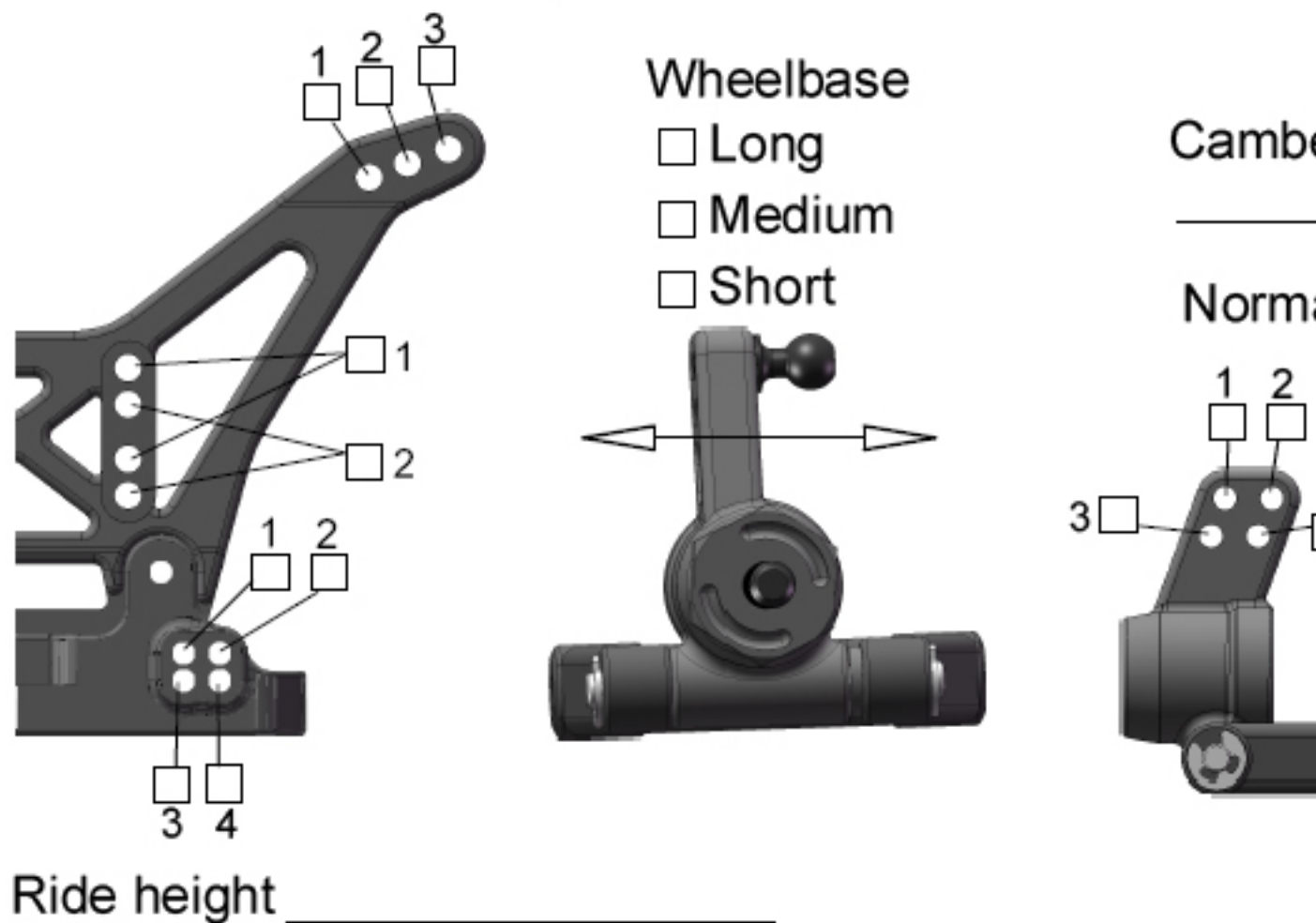

## Rear Shocks

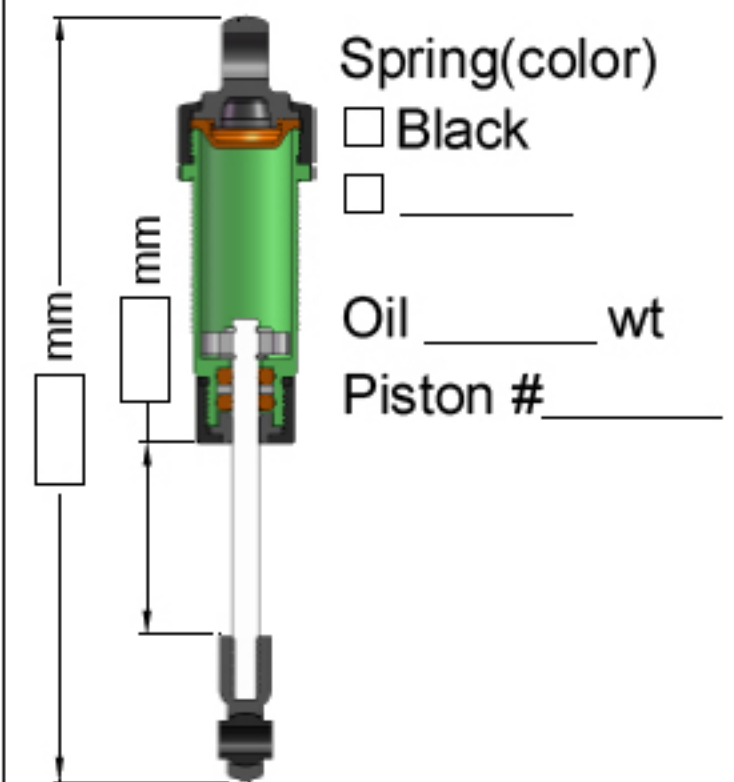

## Front Tires&Wheels

Front Tires \_\_\_\_\_  
Inserts \_\_\_\_\_ Wheels \_\_\_\_\_

## Rear Tires&Wheels

Rear Tires \_\_\_\_\_  
Inserts \_\_\_\_\_ Wheels \_\_\_\_\_

## Batteries

Servo \_\_\_\_\_  
Esc \_\_\_\_\_  
Batteries \_\_\_\_\_

## Motor

Motor \_\_\_\_\_  
Pinion/Spur \_\_\_\_\_ / \_\_\_\_\_

## Other

Wing \_\_\_\_\_  
Wing Angle  4°  10°

## Comments

Notes \_\_\_\_\_

\_\_\_\_\_

\_\_\_\_\_