

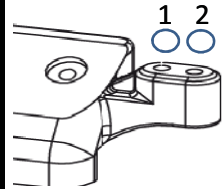

## FRONT SUSPENSION

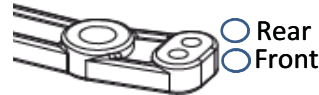
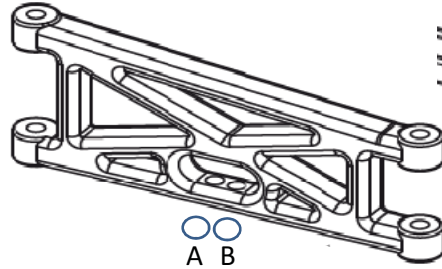

#Washers \_\_\_\_\_

Ride Height \_\_\_\_\_ mm



Caster Block

- 25°  Stock
- 30°  Alum

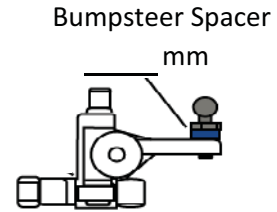

Camber \_\_\_\_\_ °

Toe In/Out \_\_\_\_\_ °

Comments: \_\_\_\_\_

## REAR SUSPENSION

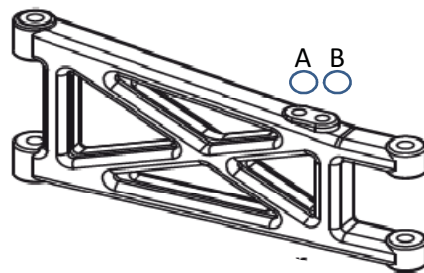
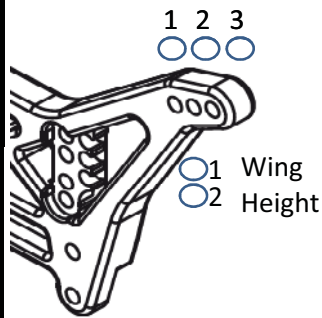

Wheelbase

- Short
- Middle
- Long

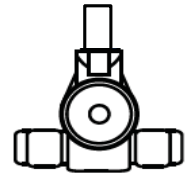

Hub Toe

- 0° (Standard)
- 0.5° (Opt)

Camber \_\_\_\_\_ °

Anti-Squat \_\_\_\_\_ °

Sway Bar \_\_\_\_\_ mm

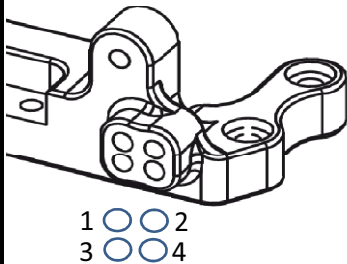

Ride Height \_\_\_\_\_ mm

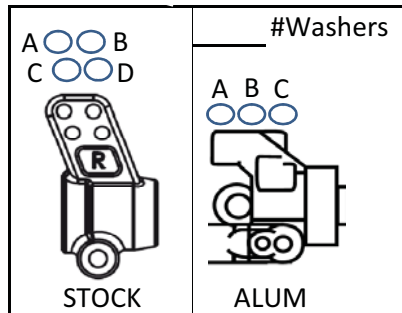

Comments: \_\_\_\_\_

## FRONT SHOCKS

PISTON# \_\_\_\_\_

SPRING \_\_\_\_\_  
 OIL \_\_\_\_\_ wt BRAND \_\_\_\_\_

LIMITERS \_\_\_\_\_

## REAR SHOCKS

PISTON# \_\_\_\_\_

SPRING \_\_\_\_\_  
 OIL \_\_\_\_\_ wt BRAND \_\_\_\_\_

LIMITERS \_\_\_\_\_

SHOCK LENGTH

\_\_\_\_\_ mm \_\_\_\_\_ mm

FRONT REAR

## FRONT TIRES & WHEELS

TIRES \_\_\_\_\_  
 INSERTS \_\_\_\_\_ WHEELS \_\_\_\_\_

## REAR TIRES & WHEELS

TIRES \_\_\_\_\_  
 INSERTS \_\_\_\_\_ WHEELS \_\_\_\_\_

Traction Compound

BODY \_\_\_\_\_ CAR WEIGHT \_\_\_\_\_  
 WING \_\_\_\_\_ ANGLE:  4°  7°  10°

MOTOR \_\_\_\_\_  
 PINION/SPUR \_\_\_\_\_ / \_\_\_\_\_

BATTERY \_\_\_\_\_  
 PLACEMENT:  FRONT  REAR

TRACK CONDITIONS: \_\_\_\_\_

COMMENTS: \_\_\_\_\_