

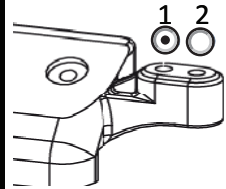

FRONT SUSPENSION

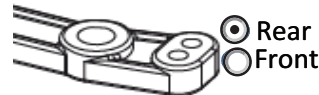
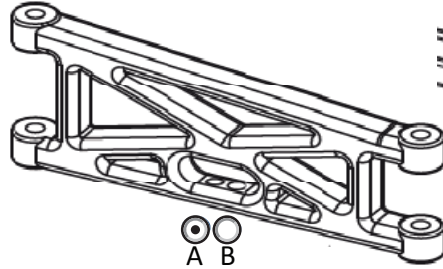

0.60" #Washers

Ride Height
24 mm



Caster Block
 25° Stock
 30° Alum

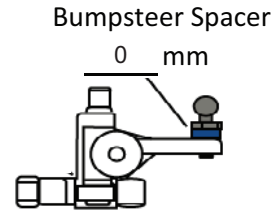

Camber -1 °

Toe In/Out 0 °

Comments: 1/4 oz in upper suspension arm mount, out front frames shock tower

REAR SUSPENSION

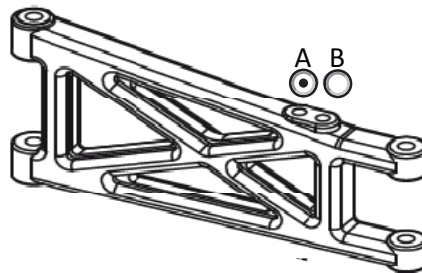
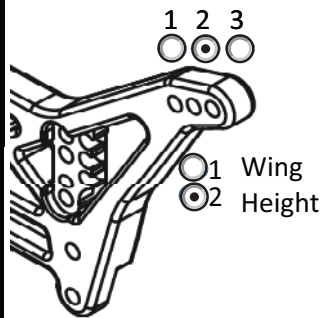

Wheelbase
 Short
 Middle
 Long

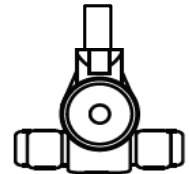

Hub Toe
 0° (Standard)
 0.5° (Opt)

Camber -1 °

Anti-Squat 0 °

Sway Bar none mm

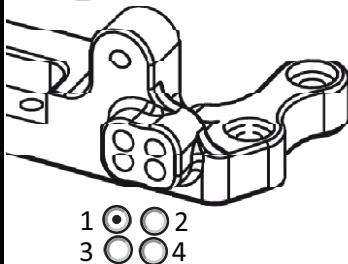

Ride Height
23 mm

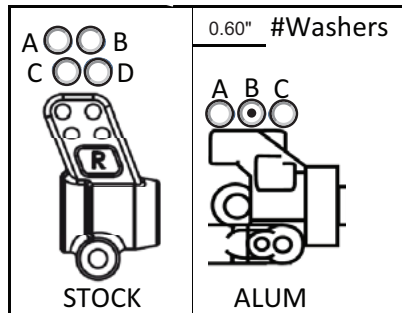

Comments: out front frames shock tower and U-Brace modification

FRONT SHOCKS

PISTON# Std
 LIMITERS 1

SPRING _____
 OIL 30 wt BRAND AE

REAR SHOCKS

PISTON# Std
 LIMITERS 1

SPRING Black
 OIL 30 wt BRAND AE

SHOCK LENGTH
 _____ mm _____ mm
 FRONT REAR

FRONT TIRES & WHEELS

TIRES JC Gold Barcodes slick
 INSERTS #/4 And-1 WHEELS TQ Yellow

REAR TIRES & WHEELS

TIRES _____
 INSERTS JC And 1 WHEELS TQ Yellow

Traction Compound
Zip Free

BODY Standard CAR WEIGHT 1545grs
 WING 6" ANGLE: 4° 7° 10°

MOTOR Speed Passion 9.5
 PINION/SPUR 26 / 78

BATTERY Desire Power 5000 45C
 PLACEMENT: FRONT REAR

TRACK CONDITIONS: High bit all weekend

COMMENTS: