

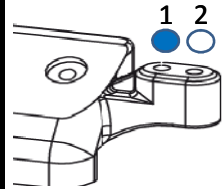

FRONT SUSPENSION

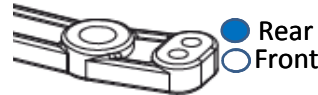
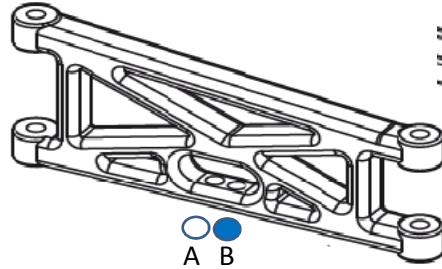

0 #Washers

Ride Height
_____ mm



Caster Block

- 25° ● Stock
- 30° ○ Alum

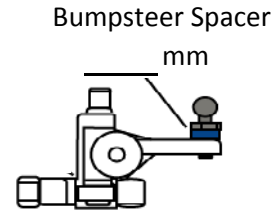

Camber _____ °

Toe In/Out _____ °

Comments: _____

REAR SUSPENSION

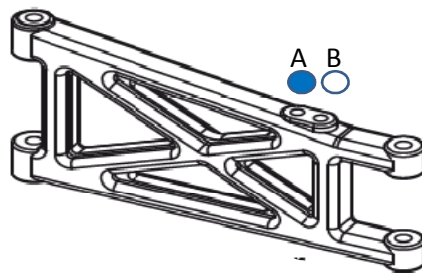
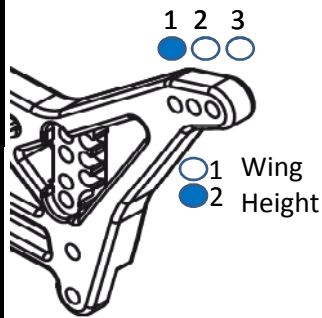

Wheelbase

- Short
- Middle
- Long

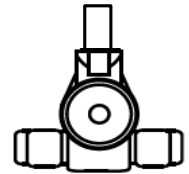

Hub Toe

- 0° (Standard)
- 0.5° (Opt)

Camber _____ °

Anti-Squat _____ °

Sway Bar _____ mm

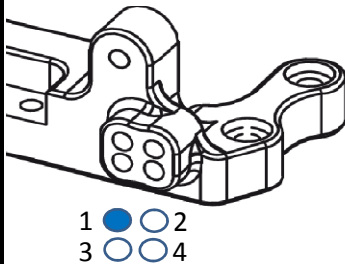

Ride Height
_____ mm

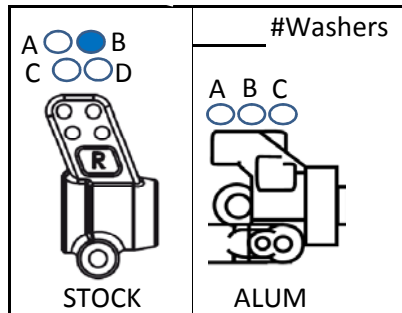

Comments: _____

FRONT SHOCKS

PISTON# Stock

SPRING BLACK

LIMITERS (-1)Turn

OIL 30 wt BRAND LOSI

REAR SHOCKS

PISTON# Stock

SPRING BLACK

LIMITERS (-1)Turn

OIL 30 wt BRAND LOSI

SHOCK LENGTH

_____ mm _____ mm

FRONT REAR

FRONT TIRES & WHEELS

TIRES _____

INSERTS _____ WHEELS _____

REAR TIRES & WHEELS

TIRES _____

INSERTS _____ WHEELS _____

Traction Compound

BODY Stock TQ

CAR WEIGHT 1545g

WING 6.5 Wide

ANGLE: ○ 4° ○ 7° ○ 10°

MOTOR Speed Passion 9.5

PINION/SPUR 25 / 80

BATTERY Desire Power 5000 45C

PLACEMENT: ○ FRONT ● REAR

TRACK CONDITIONS:

COMMENTS: 1oz weight on receiver side to balance car