

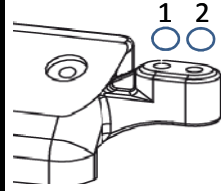

FRONT SUSPENSION

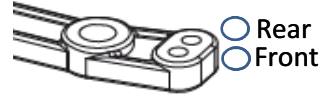

#Washers _____
 Ride Height _____ mm

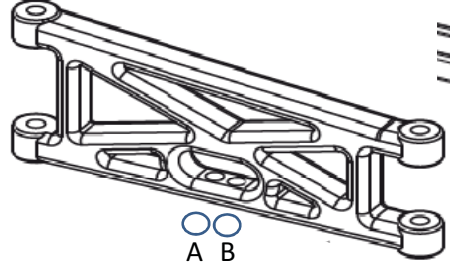
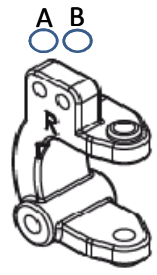

Caster Block
 25° Stock
 30° Alum

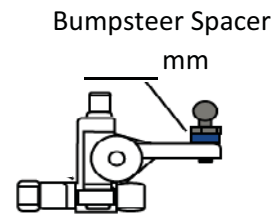

Bumpsteer Spacer _____ mm
 Camber _____ °
 Toe In/Out _____ °

Comments: _____

REAR SUSPENSION

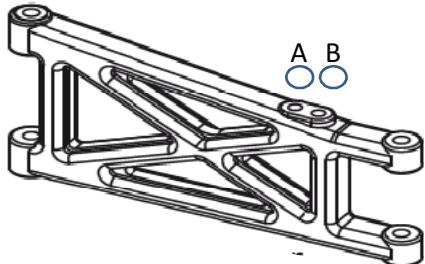
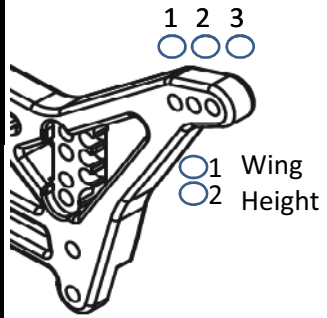

Wheelbase
 Short
 Middle
 Long

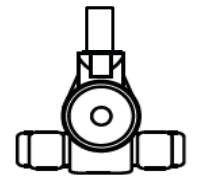

Hub Toe
 0° (Standard)
 0.5° (Opt)

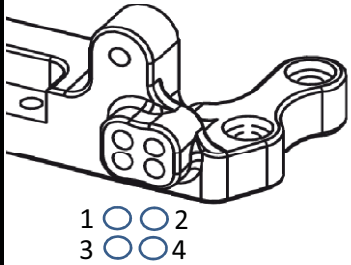

Ride Height _____ mm

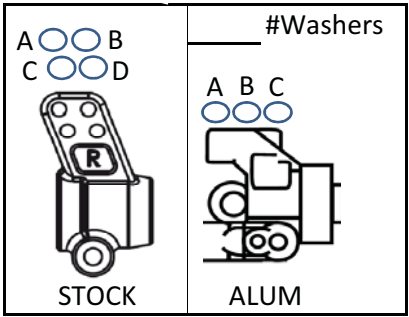

Camber _____ °
 Anti-Squat _____ °
 Sway Bar _____ mm

Comments: _____

FRONT SHOCKS

PISTON# _____
 LIMITERS _____

SPRING _____
 OIL _____ wt BRAND _____

REAR SHOCKS

PISTON# _____
 LIMITERS _____

SPRING _____
 OIL _____ wt BRAND _____

SHOCK LENGTH _____ mm
 FRONT REAR

FRONT TIRES & WHEELS

TIRES _____
 INSERTS _____ WHEELS _____

REAR TIRES & WHEELS

TIRES _____
 INSERTS _____ WHEELS _____

Traction Compound

BODY _____ CAR WEIGHT _____
 WING _____ ANGLE: 4° 7° 10°

MOTOR _____
 PINION/SPUR _____ / _____

BATTERY _____
 PLACEMENT: FRONT REAR

TRACK CONDITIONS: _____

COMMENTS: _____