



S14-3

1/10 Off Road Racing Electric Buggy
SETUP SHEET

Name: _____ Date: _____

City/Track: _____

Event: _____

Conditions: Indoor Outdoor Dry Wet Blue Groove Hard Packed

Composition: Astroturf Clay Carpet Dirt Grass Other: _____

Size: Open Medium Tight **Traction:** High Medium Low **Surface:** Smooth Medium Bumpy

Diff. Oil

Front: _____ Center: _____ Rear: _____

Tire & Inserts

Front _____ Rear _____

Tire: _____

Insert: _____

Notes: _____

Electronics

Motor: _____ Spur/Pinion: _____

Battery: _____

Battery Position: _____

ESC: _____

ESC settings: _____

Servo: _____ Receiver: _____

Front Suspension

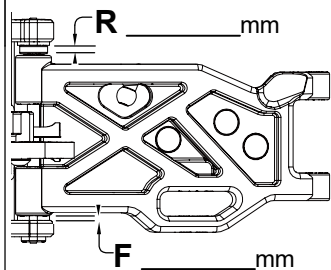
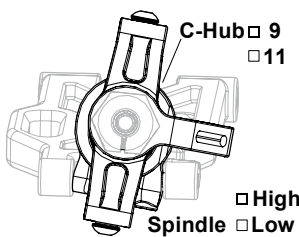
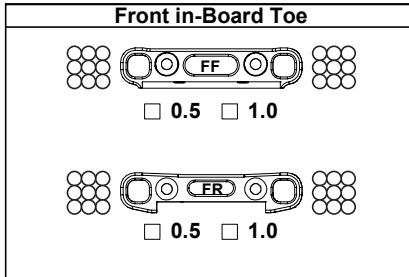
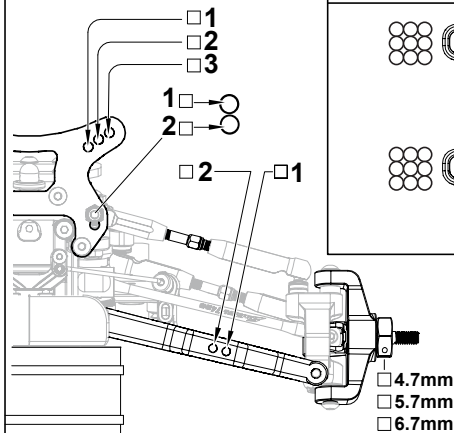

Front lower arm
 Pro-composite Hard
 Standard

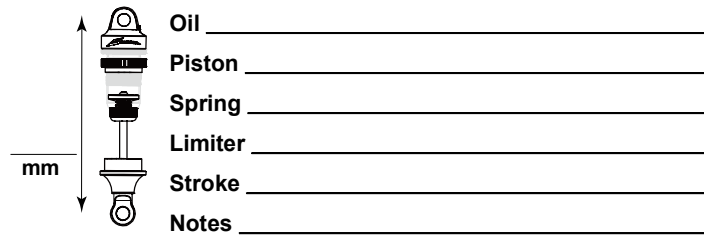
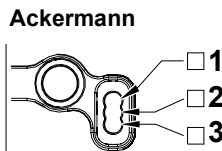

Track Width _____
Caster _____
Camber _____
Toe _____
Rebound Stop _____
Ride Height _____
Sway Bar _____

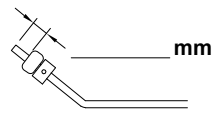

Comments

Body _____ Wing _____

Rear Suspension

Rear lower arm
 Pro-composite Hard
 Standard

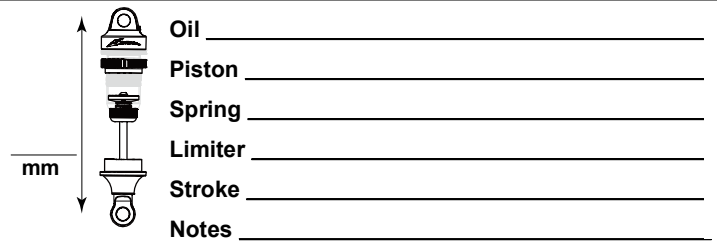
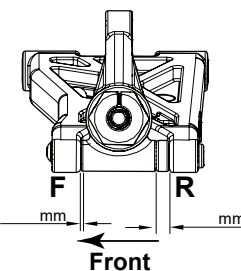
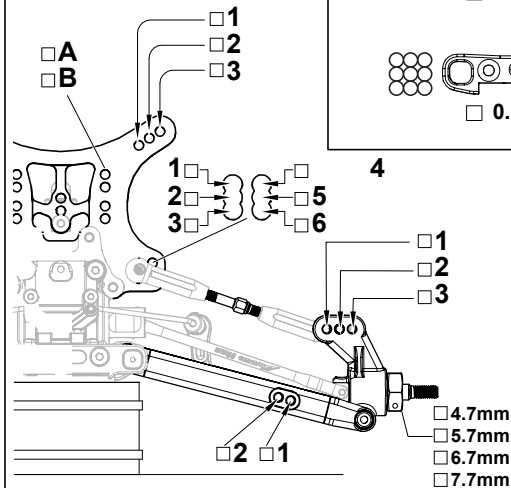
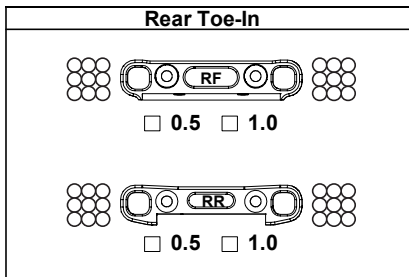

Track Width _____
Camber _____
Rebound Stop _____
Ride Height _____
Sway Bar _____

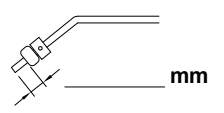

Comments

Others
Side guard Pro-Composite Hard Standard
Front T-bar Pro-Composite Hard Standard
Rear T-bar Pro-Composite Hard Standard

Comments