



S14-3

1/10 Off Road Racing Electric Buggy
SETUP SHEET

Name: _____ Date: _____

City/Track: _____

Event: _____

Conditions: Indoor Outdoor Dry Wet Blue Groove Hard Packed

Composition: Astroturf Clay Carpet Dirt Grass Other: _____

Size: Open Medium Tight Traction: High Medium Low Surface: Smooth Medium Bumpy

Diff. Oil

Front: _____ Center: _____ Rear: _____

Tire & Inserts

Front

Rear

Tire: _____

Insert: _____

Notes: _____

Electronics

Motor: _____ Spur/Pinion: _____

Battery: _____

Battery Position: _____

ESC: _____

ESC settings: _____

Servo: _____ Receiver: _____

Front Suspension

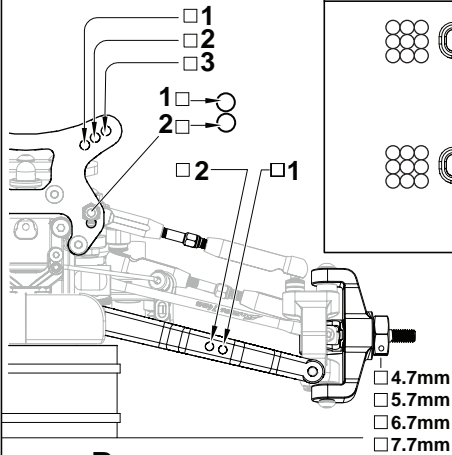

Front in-Board Toe



0.5 1.0



0.5 1.0

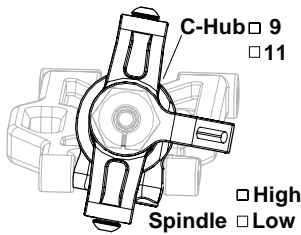

Front lower arm
 Pro-composite Hard
 Standard

Ackermann

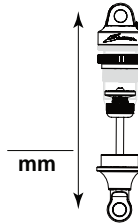
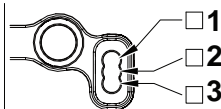

Oil _____

Piston _____

Spring _____

Limiter _____

Stroke _____

Track Width _____

Caster _____

Camber _____

Toe _____

Rebound Stop _____

Ride Height _____

Sway Bar _____

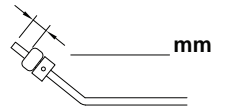

R _____ mm

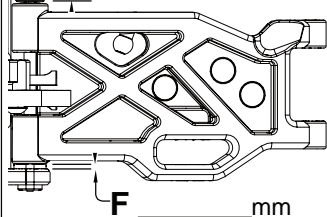

F _____ mm

Comments

Body _____ Wing _____

Rear Suspension

Rear lower arm
 Pro-composite Hard
 Standard

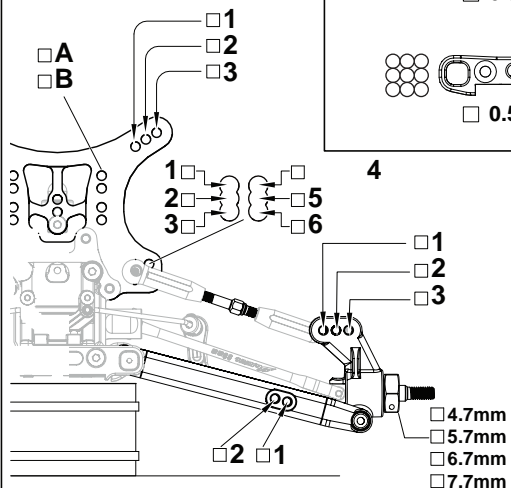

Rear Toe-In



0.5 1.0



0.5 1.0

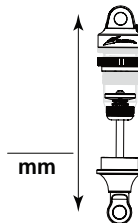
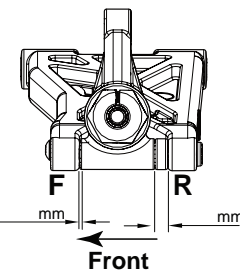

Oil _____

Piston _____

Spring _____

Limiter _____

Stroke _____

Track Width _____

Camber _____

Rebound Stop _____

Ride Height _____

Sway Bar _____

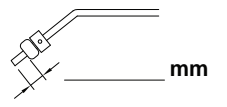

Others

Side guard Pro-Composite Hard Standard
Front T-bar Pro-Composite Hard Standard
Rear T-bar Pro-Composite Hard Standard

Arn0 - PetitRC.com

Comments