



S14-3

1/10 Off Road Racing Electric Buggy
SETUP SHEET

Name: vialle arnaudDate 2/12/2018

City/Track: _____

Event: gp limogesConditions: Indoor Outdoor Dry Wet Blue Groove Hard PackedComposition: Astroturf Clay Carpet Dirt Grass Other: _____Size: Open Medium Tight Traction: High Medium Low Surface: Smooth Medium Bumpy

Diff. Oil

Front: 10000 Center: slipper Rear: 7000

Tire & Inserts

Front Rear
Tire: 6mik crunch 6mikcrunch 2.0
Insert: insert foam

Notes: _____

Electronics

Motor: 5.5 v10 Spur/Pinion: 19 / 81

Battery: _____

Battery Position: frontESC: xr10 proESC settings: 4wd mod

Servo: _____ Receiver: _____

Front Suspension

Front in-Board Toe	
<input type="checkbox"/> 0	<input type="checkbox"/> 0
<input type="checkbox"/> ±0.5	<input type="checkbox"/> ±0.5
<input type="checkbox"/> ±1.0	<input type="checkbox"/> ±1.0
<input type="checkbox"/> ±0.5+1K-UP	<input type="checkbox"/> ±0.5+1K-UP
<input checked="" type="checkbox"/> ±1.0+1K-UP	<input checked="" type="checkbox"/> ±1.0+1K-UP

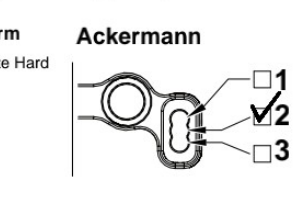
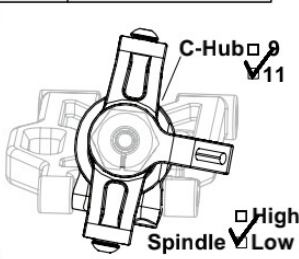
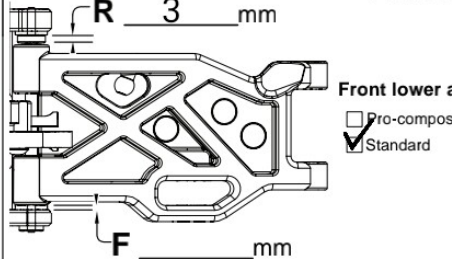
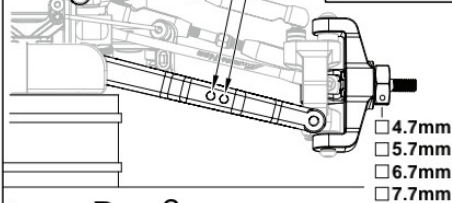

Oil 50 donuts racing
 Piston 2x1,6
 Spring kit
 Limiter 1mm
 Stroke _____
 Notes _____

Track Width _____
 Caster 11
 Camber 2
 Toe -1
 Rebound Stop 0
 Ride Height 14 mm
 Sway Bar 1.3

Body _____ kit _____
 Wing _____ kit _____

Rear Suspension

Rear lower arm

Pro-composite Hard
 Standard

Rear Toe-In	
<input type="checkbox"/> 0	<input type="checkbox"/> 0
<input type="checkbox"/> ±0.5	<input type="checkbox"/> ±0.5
<input type="checkbox"/> ±1.0	<input type="checkbox"/> ±1.0
<input checked="" type="checkbox"/> ±0.5+1K-UP	<input type="checkbox"/> ±0.5+1K-UP
<input type="checkbox"/> ±1.0+1K-UP	<input checked="" type="checkbox"/> ±1.0+1K-UP

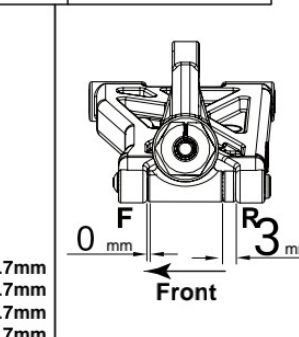
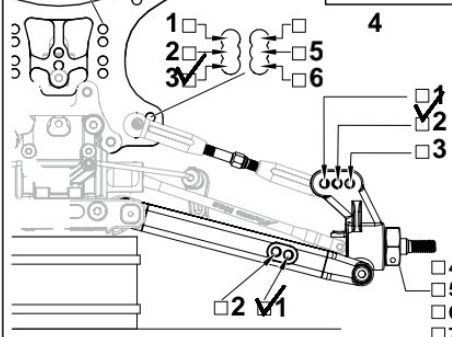

Oil 42.5 donuts racing
 Piston 2x1.7
 Spring kit
 Limiter 2.5
 Stroke _____
 Notes _____

Track Width _____
 Camber 2
 Rebound Stop 0
 Ride Height 15 mm
 Sway Bar 1.8

Others

Side guard Pro-Composite Hard Standard
 Front T-bar Pro-Composite Hard Standard
 Rear T-bar Pro-Composite Hard Standard

Arno - PetitRC.com
 polissage des tiges d'amortisseurs et graissage des o-rings avec la donuts racing grease-o-ring (bleu)