

Conditions:  Indoor  Outdoor  Dry  Wet  Blue Groove  Hard Packed  
 Composition:  AstroTurf  Clay  Carpet  Dirt  Grass  Other: \_\_\_\_\_  
 Size:  Open  Medium  Tight Traction:  High  Medium  Low Surface:  Smooth  Medium  Bumpy

**Diff. Oil**  
 Front: 20k Center: 500k Rear: 15k

**Tire & Inserts**  
 Front Rear  
 Tire: Wide Cut Stagger Mini Pin 2 Yellow  
 Insert: medium front tubby rear  
 Notes: row off outside of rears

**Electronics**  
 Motor: LRP X20 5.5 Spur/Pinion: Kit  
 Battery: Orion Shorty  
 Battery Position: Forward  
 ESC: LRP Flow Works Team  
 ESC settings: \_\_\_\_\_  
 Servo: Xpert Receiver: Sanwa

### Front Suspension

**Front in-Board Toe**

<input type="checkbox"/> 0	<input checked="" type="checkbox"/> -1	<input type="checkbox"/> 0	<input checked="" type="checkbox"/> -1
<input type="checkbox"/> +1	<input type="checkbox"/> 0	<input type="checkbox"/> 0	<input type="checkbox"/> +1

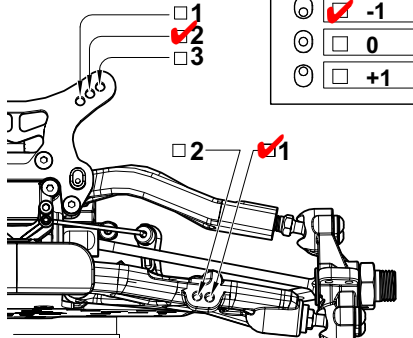

Wheel Rebound Stop  
 R: \_\_\_\_\_ mm  
 F: 3 mm

**Front Shocks**  
 Oil: 50wt  
 Piston: 1.5  
 Spring: AE Orange  
 Limiter: \_\_\_\_\_

Body: \_\_\_\_\_  
 Wing: YZ2  
 Notes: \_\_\_\_\_

**Front Roll Center**

<input checked="" type="checkbox"/> Left	<input type="checkbox"/> Right	<input type="checkbox"/> Left	<input checked="" type="checkbox"/> Right
--	--------------------------------	-------------------------------	---

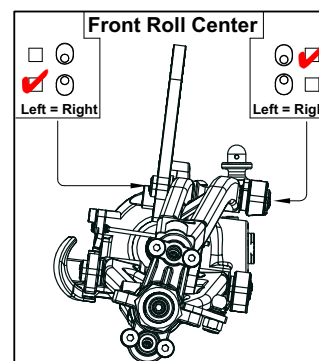

Sway Bar: 1.3  
 \_\_\_\_\_ mm

Track Width: \_\_\_\_\_  
 Caster: \_\_\_\_\_  
 Camber: -2  
 Toe: 1  
 Rebound Stop: \_\_\_\_\_  
 Ride Height: 18mm  
 Sway Bar: 1.3

**Steering Ackerman**

<input type="checkbox"/> 0	<input checked="" type="checkbox"/> 1	<input type="checkbox"/> _____ mm
----------------------------	---------------------------------------	-----------------------------------

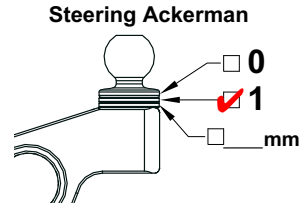

### Rear Suspension

**Rear Toe-In**

<input type="checkbox"/> -1	<input checked="" type="checkbox"/> -1	<input type="checkbox"/> 0	<input checked="" type="checkbox"/> 0
<input type="checkbox"/> +1	<input type="checkbox"/> 0	<input type="checkbox"/> 0	<input type="checkbox"/> +1

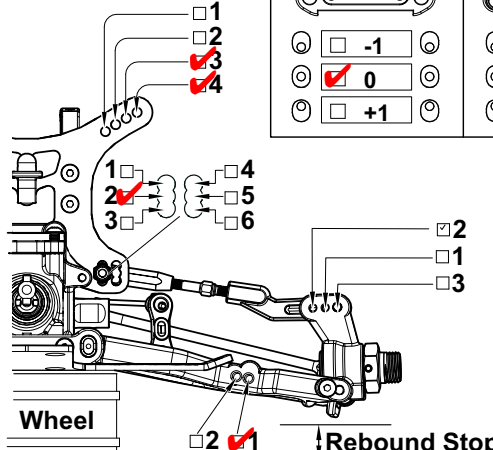

Wheel Rebound Stop  
 \_\_\_\_\_ mm

**Rear Shocks**  
 Oil: 35wt  
 Piston: 1.5  
 Spring: AE Grey  
 Limiter: \_\_\_\_\_

Sway Bar: 1.5  
 \_\_\_\_\_ mm

**Front**

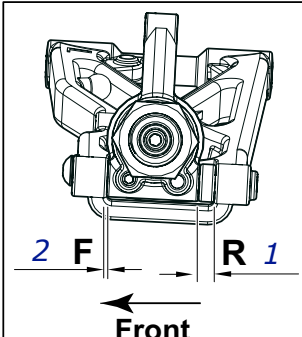

Track Width: \_\_\_\_\_  
 Camber: -2  
 Rebound Stop: \_\_\_\_\_  
 Ride Height: 18mm  
 Notes: 3mm removed from rear arms. wheelbase 280mm