

Name: Stephen Smith Date: _____

City/Track: _____

Event: _____

Conditions: Indoor Outdoor Dry Wet Blue Groove Hard Packed
Composition: Astroturf Clay Carpet Dirt Grass Other: Wood
Size: Open Medium Tight **Traction:** High Medium Low **Surface:** Smooth Medium Bumpy

Diff. Oil
 Front: 20k Center: Slipper Rear: 10k

Electronics
 Motor: LRP X20 6.5 Spur/Pinion: Kit/Kit
 Battery: Shorty
 Battery Position: Back
 ESC: _____
 ESC settings: _____
 Servo: _____ Receiver: _____

Tire & Inserts

Front	Rear
Tire: _____	Tire: _____
Insert: _____	Insert: _____
Notes: _____	Notes: _____

Front Suspension

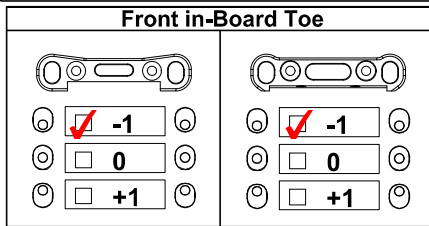

Front Shocks
 Oil: 650
 Piston: 2x1.4
 Spring: AE Purple
 Limiter: _____

Body: Sworz
 Wing: Sw Sonic

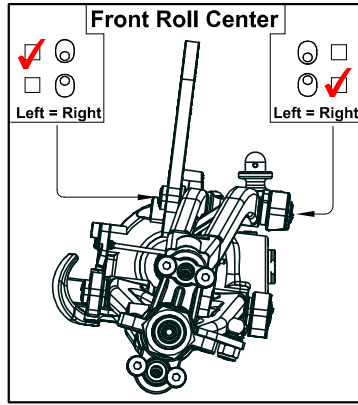
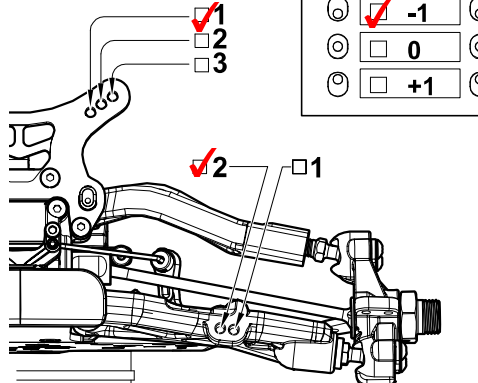

Notes: _____
 Track Width: Kit
 Caster: Max
 Camber: -2
 Toe: +1
 Rebound Stop: _____
 Ride Height: 18mm
 Sway Bar: 1.6

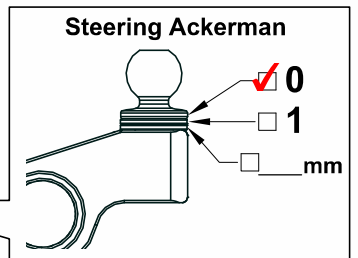
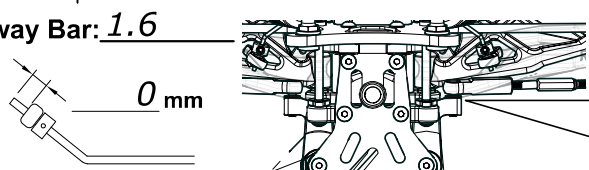
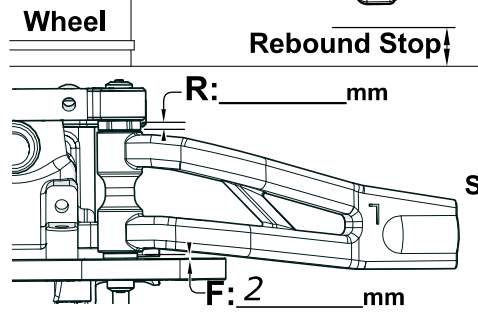

Rear Suspension

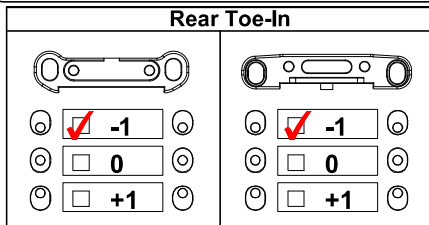

Rear Shocks
 Oil: 450
 Piston: 2x1.5
 Spring: AE Grey
 Limiter: 2mm

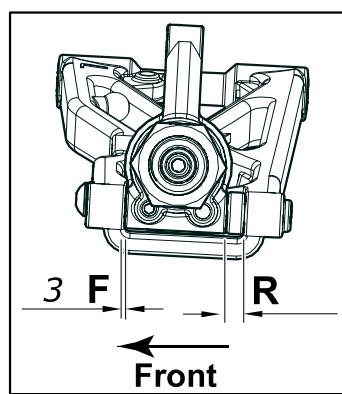
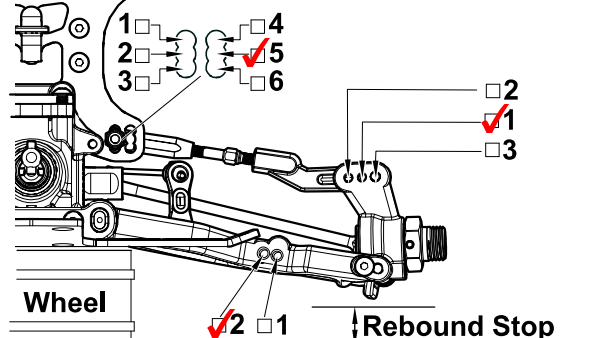
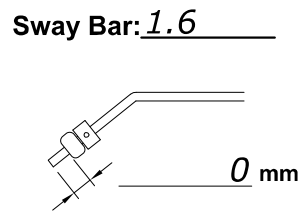

Notes: _____
 Track Width: Kit
 Camber: -2
 Rebound Stop: _____
 Ride Height: 18mm