

Name: \_\_\_\_\_ Date: \_\_\_\_\_

City/Track: \_\_\_\_\_

Event: \_\_\_\_\_

Conditions:  Indoor  Outdoor  Dry  Wet  Blue Groove  Hard Packed

Composition:  Astroturf  Clay  Carpet  Dirt  Grass  Other: \_\_\_\_\_

Size:  Open  Medium  Tight Traction:  High  Medium  Low Surface:  Smooth  Medium  Bumpy

**Diff. Oil**  
 Front: \_\_\_\_\_ Center: \_\_\_\_\_ Rear: \_\_\_\_\_

**Electronics**  
 Motor: \_\_\_\_\_ Spur/Pinion: \_\_\_\_\_  
 Battery: \_\_\_\_\_  
 Battery Position: \_\_\_\_\_  
 ESC: \_\_\_\_\_  
 ESC settings: \_\_\_\_\_  
 Servo: \_\_\_\_\_ Receiver: \_\_\_\_\_

**Tire & Inserts**  
 Front Rear  
 Tire: \_\_\_\_\_  
 Insert: \_\_\_\_\_  
 Notes: \_\_\_\_\_

**Front Suspension**

Shock Tower: \_\_\_\_\_

**Front in-Board Toe**

<input type="checkbox"/> -1	<input type="checkbox"/> -1
<input type="checkbox"/> 0	<input type="checkbox"/> 0
<input type="checkbox"/> +1	<input type="checkbox"/> +1

**Front Shocks:** \_\_\_\_\_  
 Oil: \_\_\_\_\_  
 Piston: \_\_\_\_\_  
 Spring: \_\_\_\_\_  
 Limiter: \_\_\_\_\_  
 Stroke: \_\_\_\_\_

Body: \_\_\_\_\_  
 Wing: \_\_\_\_\_

Notes: \_\_\_\_\_

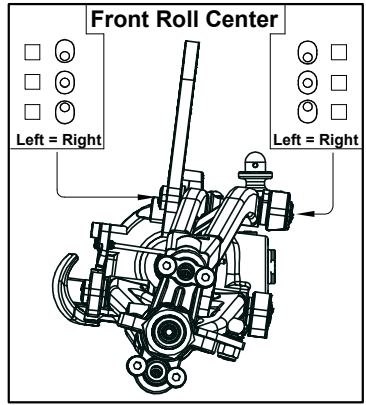
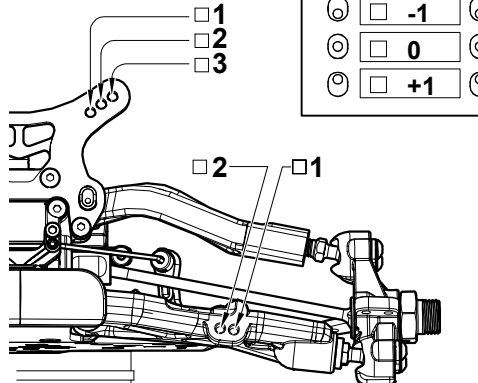

Track Width: \_\_\_\_\_  
 Caster: \_\_\_\_\_  
 Camber: \_\_\_\_\_  
 Toe: \_\_\_\_\_  
 Rebound Stop: \_\_\_\_\_  
 Ride Height: \_\_\_\_\_  
 Sway Bar: \_\_\_\_\_

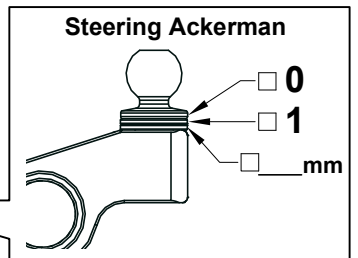
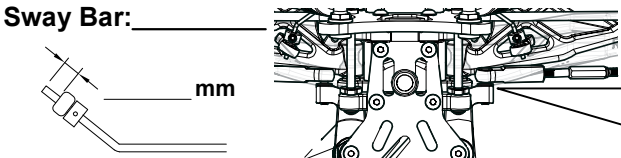
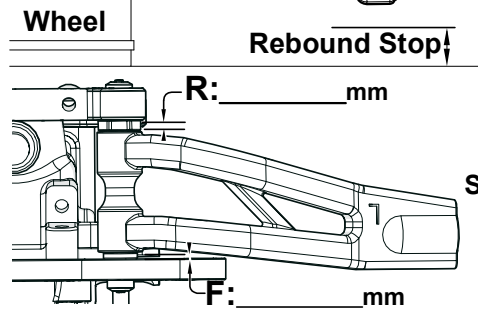

**Rear Suspension**

Shock Tower: \_\_\_\_\_

**Rear Toe-In**

<input type="checkbox"/> -1	<input type="checkbox"/> -1
<input type="checkbox"/> 0	<input type="checkbox"/> 0
<input type="checkbox"/> +1	<input type="checkbox"/> +1

**Rear Shocks:** \_\_\_\_\_  
 Oil: \_\_\_\_\_  
 Piston: \_\_\_\_\_  
 Spring: \_\_\_\_\_  
 Limiter: \_\_\_\_\_  
 Stroke: \_\_\_\_\_

**Sway Bar:** \_\_\_\_\_

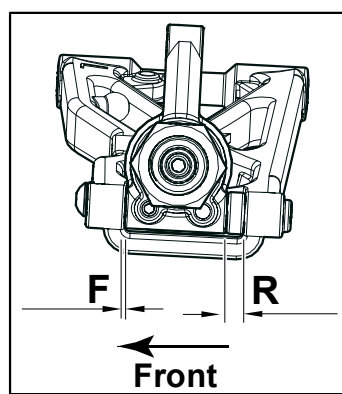
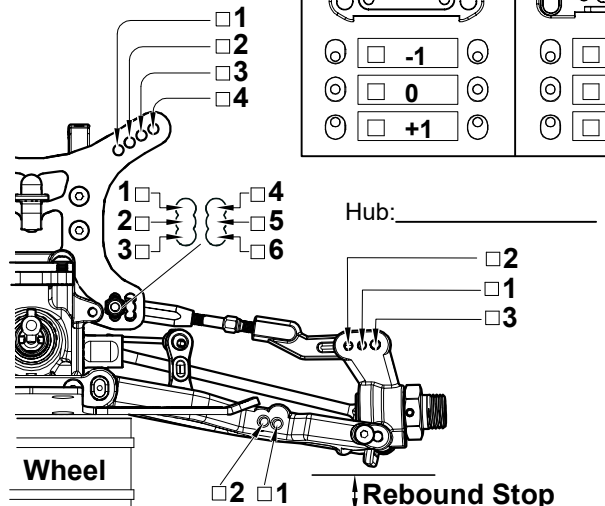
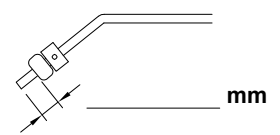

Track Width: \_\_\_\_\_  
 Camber: \_\_\_\_\_  
 Rebound Stop: \_\_\_\_\_  
 Ride Height: \_\_\_\_\_  
 Notes: \_\_\_\_\_