

Name: _____ Date: _____

City/Track: _____

Event: _____

Conditions: Indoor Outdoor Dry Wet Blue Groove Hard Packed

Composition: Astroturf Clay Carpet Dirt Grass Other: _____

Size: Open Medium Tight Traction: High Medium Low Surface: Smooth Medium Bumpy

Diff. Oil
 Front: _____ Center: _____ Rear: _____

Electronics
 Motor: _____ Spur/Pinion: _____
 Battery: _____
 Battery Position: _____
 ESC: _____
 ESC settings: _____
 Servo: _____ Receiver: _____

Tire & Inserts
 Front Rear
 Tire: _____
 Insert: _____
 Notes: _____

Front Suspension

Shock Tower: _____

Front in-Board Toe

<input type="checkbox"/> -1	<input type="checkbox"/> -1
<input type="checkbox"/> 0	<input type="checkbox"/> 0
<input type="checkbox"/> +1	<input type="checkbox"/> +1

Front Shocks: _____
 Oil: _____
 Piston: _____
 Spring: _____
 Limiter: _____
 Stroke: _____

Body: _____
 Wing: _____

Notes: _____

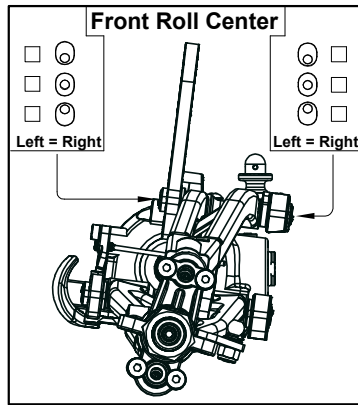
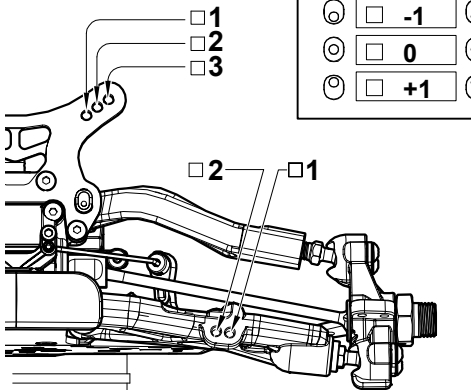

Track Width: _____
 Caster: _____
 Camber: _____
 Toe: _____
 Rebound Stop: _____
 Ride Height: _____
 Sway Bar: _____

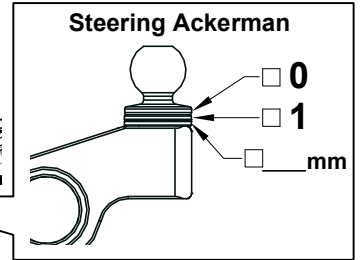
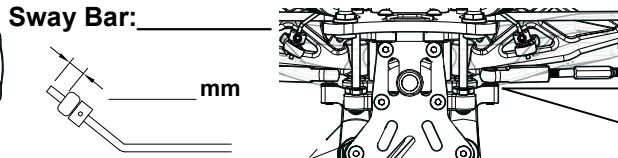
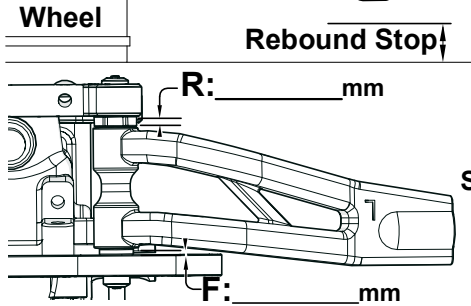

Rear Suspension

Shock Tower: _____

Rear Toe-In

<input type="checkbox"/> -1	<input type="checkbox"/> -1
<input type="checkbox"/> 0	<input type="checkbox"/> 0
<input type="checkbox"/> +1	<input type="checkbox"/> +1

Rear Shocks: _____
 Oil: _____
 Piston: _____
 Spring: _____
 Limiter: _____
 Stroke: _____

Sway Bar: _____

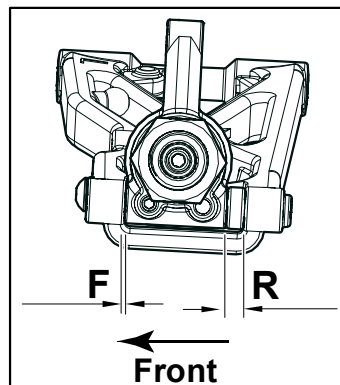
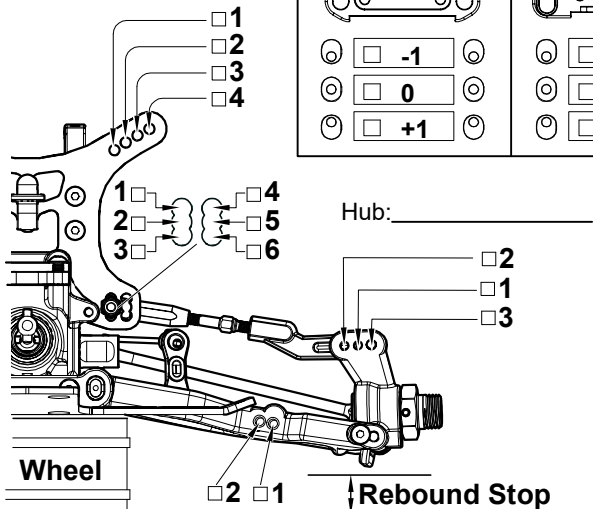
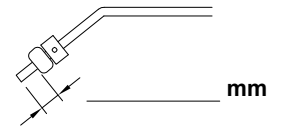

Track Width: _____
 Camber: _____
 Rebound Stop: _____
 Ride Height: _____
 Notes: _____