



Swork S121M Setup Sheet

Name: _____ Date: _____
 City/Track: _____
 Event: _____

Conditions: Indoor Outdoor Dry Wet Blue Groove Hard Packed
 Composition: AstroTurf Clay Carpet Dirt Grass Other: _____
 Size: Open Medium Tight Traction: High Medium Low Surface: Smooth Medium Bumpy

Differential
 Ball: _____ Gear - Oil: _____

Tire & Inserts
 Front Rear
 Tire: _____
 Insert: _____
 Notes: _____

Electronics
 Motor: _____ Spur/Pinion: _____
 Battery: _____
 Battery Position: _____
 ESC: _____
 ESC settings: _____
 Servo: _____ Receiver: _____

Front Suspension

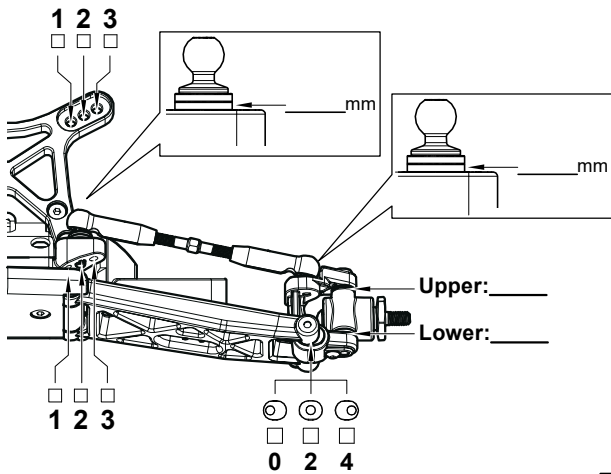

Camber: _____
 Toe: _____
 Ride Height: _____

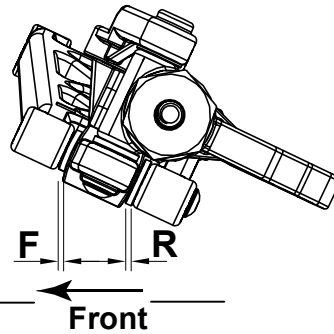

Front Shocks
 Oil: _____
 Piston: _____
 Spring: _____
 Preload: _____
 Limiter - In: _____ Out: _____

Notes: _____

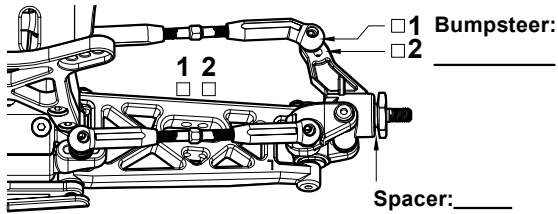

Arm Holder Spacer
 0.5mm 1mm

Caster
 25° 30°

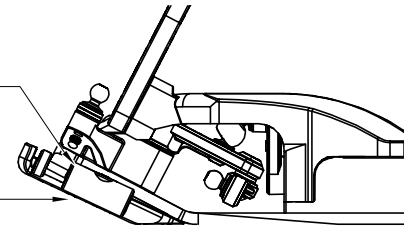

Rear Suspension

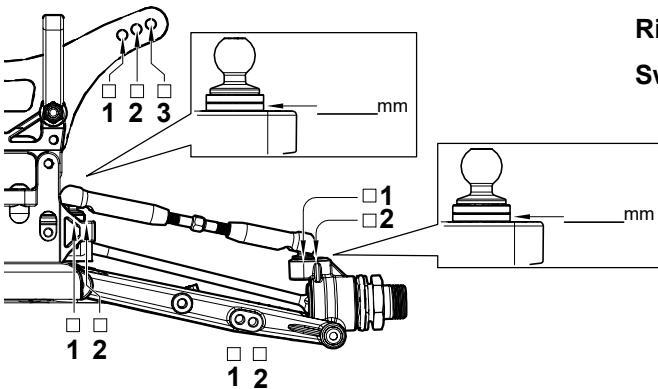

Camber: _____
 Ride Height: _____
 Swaybar: _____

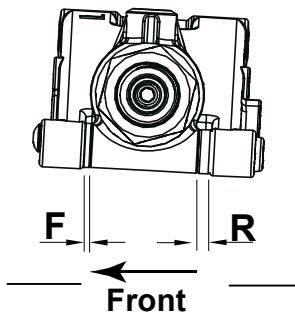

Rear Shocks
 Oil: _____
 Piston: _____
 Spring: _____
 Preload: _____
 Limiter - In: _____ Out: _____

Body: _____
 Wing: _____
 Notes: _____

Wing spacer _____ mm



Rear Toe-in

<input type="checkbox"/> -1	<input type="checkbox"/> -1
<input type="checkbox"/> 0	<input type="checkbox"/> 0
<input type="checkbox"/> +1	<input type="checkbox"/> +1

Notes: _____