

DRIVER, TRACK AND RESULTS

DRIVER *Shin Adachi* COUNTRY *Japan* WEATHER AIR TEMP TRACK TEMP DRY INTERMEDIATE WET
RACE *FEMCA 2016* DATE *2016/MAY/28* QUALY POS. *5* STARTING POS. *2* FINAL POS. *2* FASTEST LAP *38.6*
TRACK *RC tracks of Las Vegas* TYPE TIGHT MEDIUM OPEN GRIP LOW MEDIUM HIGH
SURFACE CONDITION SMOOTH ROUGH
TYPE HARD PACKED CLAY MULTI/SURFACE GRASS BLUE GROOVE DIRT ASTRO-TURF

FRONT SHOCK ABSORBERS		REAR
TLR <i>42.5</i> cst	OIL	TLR <i>35</i> cst
<i>HB gold</i>	SPRINGS	<i>HB blue</i>
<i>10</i> mm	REBOUND	<i>10</i> mm
N° HOLES <i>5</i> Ø <i>1.5</i> mm	PISTONS	N° HOLES <i>5</i> Ø <i>1.5</i> mm
<input checked="" type="checkbox"/> BLADDER	SEAL TYPE	<input checked="" type="checkbox"/> BLADDER
<input type="checkbox"/> EMULSION		<input type="checkbox"/> EMULSION

FRONT ANTI-ROLL BARS		REAR
<input type="checkbox"/> 1.8	<input type="checkbox"/> 2.0	<input checked="" type="checkbox"/> 2.3
<input type="checkbox"/> 2.5	<input type="checkbox"/> 2.7	<input type="checkbox"/> 1.8
<input type="checkbox"/> 2.0	<input type="checkbox"/> 2.3	<input type="checkbox"/> 2.5
<input type="checkbox"/> 2.5	<input type="checkbox"/> 2.7	<input type="checkbox"/> 2.7

DIFFERENTIAL OIL		
FRONT DIFF <i>10K</i> cst	CENTER DIFF <i>10K</i> cst	REAR DIFF <i>3K</i> cst

GEARING	
CLUTCH BELL <i>13</i> Teeth	SPUR GEAR <i>46</i> Teeth

CLUTCH	
<input type="checkbox"/> STANDARD <input checked="" type="checkbox"/> VENTED	<input type="checkbox"/> STEEL <input checked="" type="checkbox"/> ALU
CLUTCH SHOES	CLUTCH SPRINGS
SHOE TYPE <i>Carbon</i> x <i>2</i> with SPRINGS TYPE <i>.9</i> mm	
SHOE TYPE <i>Alu</i> x <i>2</i> with SPRINGS TYPE <i>.9</i> mm	

ENGINE, PIPE AND FUEL	
ENGINE BRAND <i>OS speed</i>	TYPE <i>2101</i>
HEADSHIMS mm	GLOWPLUG <i>P3</i> CARB Ø <i>6.0</i> mm
EXHAUST PIPE <i>OS 2090</i>	MANIFOLD
FUEL BRAND <i>Oopti</i>	NITRO <i>25%</i>

FLEX CONFIGURATION	
ENGINE MOUNT	<input type="checkbox"/> STANDARD <input checked="" type="checkbox"/> MONOBLOCK

AERODYNAMIC CONFIGURATION	
BODY <input checked="" type="checkbox"/> STANDARD <input type="checkbox"/> HIGH DOWNFORCE <input type="checkbox"/> OTHER	
WING	
TYPE <i>STX8</i>	WING PLATES <input type="checkbox"/> 2° <input checked="" type="checkbox"/> 4° <input type="checkbox"/> 6°
GURNEY STRIP <input checked="" type="checkbox"/> YES <input type="checkbox"/> NO	CENTER FOIL <input type="checkbox"/> YES <input type="checkbox"/> NO

FRONT TIRES		Controlled Tire	REAR
<i>AKA</i>	MAKE	<input checked="" type="checkbox"/>	<i>AKA</i>
<i>Impact</i>	TYPE		<i>Impact</i>
<i>AKA</i>	INSERTS		<i>AKA</i>
<i>AKA Evo</i>	WHEELS		<i>AKA Evo</i>

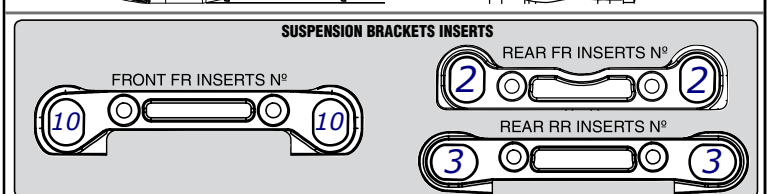
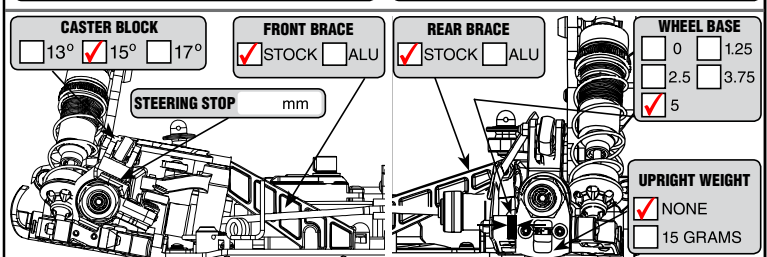
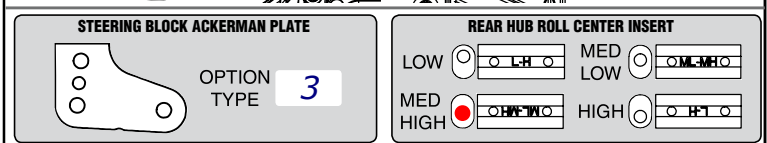
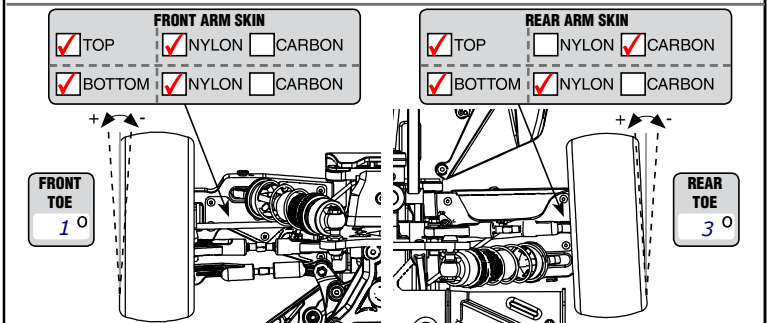
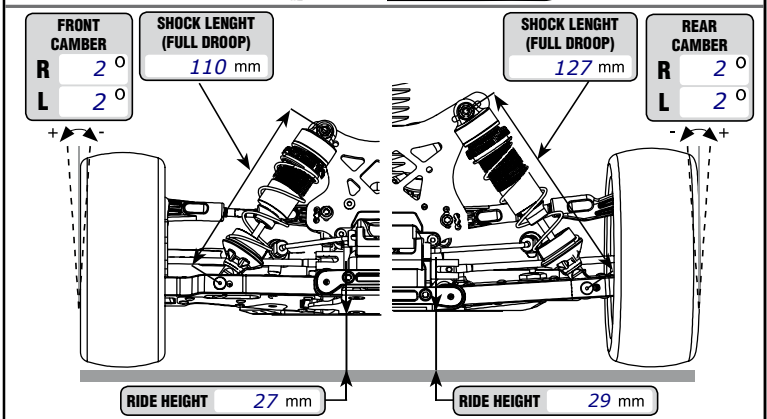
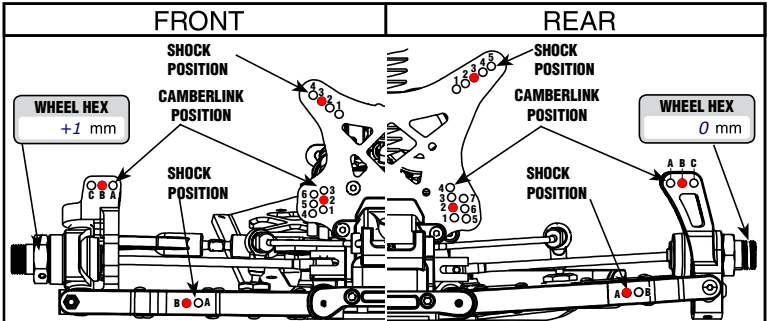

REMARKS *Aluminum shock tower front and rear
2.4mm rear sway bar*