

## DRIVER, TRACK AND RESULTS

**DRIVER** \_\_\_\_\_ **COUNTRY** \_\_\_\_\_ **WEATHER** AIR TEMP \_\_\_\_\_ TRACK TEMP \_\_\_\_\_  DRY  INTERMEDIATE  WET  
**RACE** \_\_\_\_\_ **DATE** \_\_\_\_\_ **QUALY POS.** \_\_\_\_\_ **STARTING POS.** \_\_\_\_\_ **FINAL POS.** \_\_\_\_\_ **FASTEST LAP** \_\_\_\_\_  
**TRACK** \_\_\_\_\_ **TYPE**  TIGHT  MEDIUM  OPEN  **GRIP**  LOW  MEDIUM  HIGH   
**SURFACE CONDITION**  SMOOTH  ROUGH   
**TYPE**  HARD PACKED  CLAY  MULTI/SURFACE  GRASS  BLUE GROOVE  DIRT  ASTRO-TURF

FRONT SHOCK ABSORBERS		REAR	
cst	OIL	cst	
SPRINGS			
mm REBOUND		mm	
N° HOLES	∅ mm	PISTONS N° HOLES	∅ mm
<input type="checkbox"/> BLADDER	SEAL	<input type="checkbox"/> BLADDER	
<input type="checkbox"/> EMULSION	TYPE	<input type="checkbox"/> EMULSION	

FRONT ANTI-ROLL BARS		REAR	
<input type="checkbox"/>	<input type="checkbox"/>	<input type="checkbox"/>	<input type="checkbox"/>
1.8	2.0	2.3	2.5
2.7	1.8	2.0	2.3
2.5	2.7	2.5	2.7

**DIFFERENTIAL OIL**

FRONT DIFF cst \_\_\_\_\_ CENTER DIFF cst \_\_\_\_\_ REAR DIFF cst \_\_\_\_\_

**GEARING**

CLUTCH BELL \_\_\_\_\_ Teeth \_\_\_\_\_ SPUR GEAR \_\_\_\_\_ Teeth \_\_\_\_\_

**CLUTCH**

CLUTCH BELL STANDARD  VENTED  FLYWHEEL STEEL  ALU

CLUTCH SHOES \_\_\_\_\_ x \_\_\_\_\_ with SPRINGS TYPE \_\_\_\_\_ mm  
 SHOE TYPE \_\_\_\_\_ x \_\_\_\_\_ with SPRINGS TYPE \_\_\_\_\_ mm

**ENGINE, PIPE AND FUEL**

ENGINE BRAND \_\_\_\_\_ TYPE \_\_\_\_\_  
 HEADSHIMS mm GLOWPLUG \_\_\_\_\_ CARB ∅ mm  
 EXHAUST PIPE \_\_\_\_\_ MANIFOLD \_\_\_\_\_  
 FUEL BRAND \_\_\_\_\_ NITRO % \_\_\_\_\_

**FLEX CONFIGURATION**

ENGINE MOUNT  STANDARD  MONOBLOCK

**AERODYNAMIC CONFIGURATION**

BODY  STANDARD  HIGH DOWNFORCE  OTHER \_\_\_\_\_  
**WING**  
 TYPE \_\_\_\_\_ WING PLATES  2°  4°  6°  
 GURNEY STRIP  YES  NO CENTER FOIL  YES  NO

FRONT TIRES	Controlled Tire	REAR
MAKE	<input type="checkbox"/>	
TYPE		
INSERTS		
WHEELS		

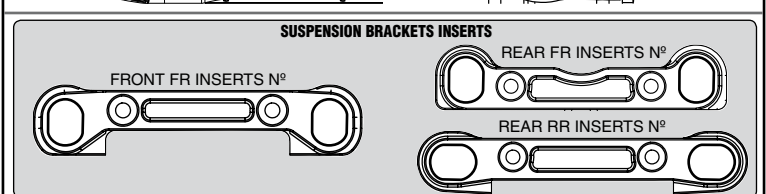
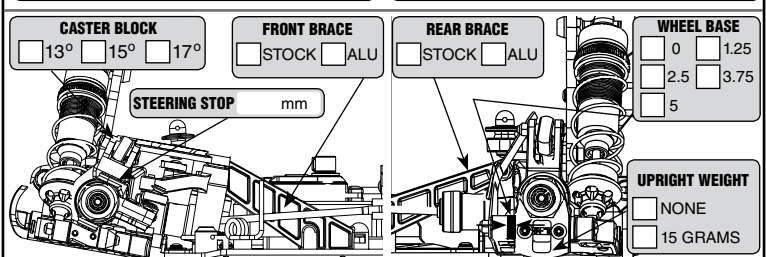
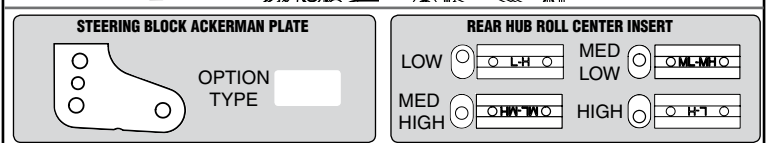
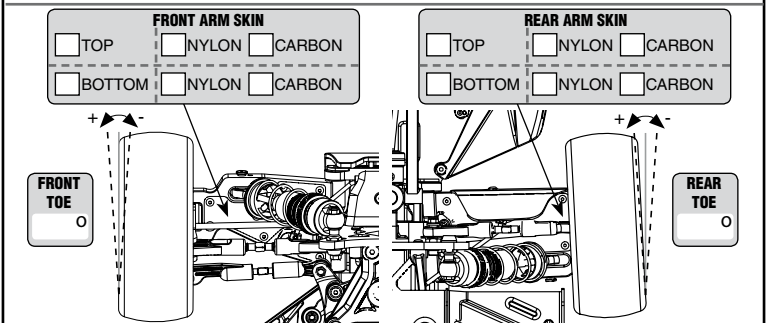
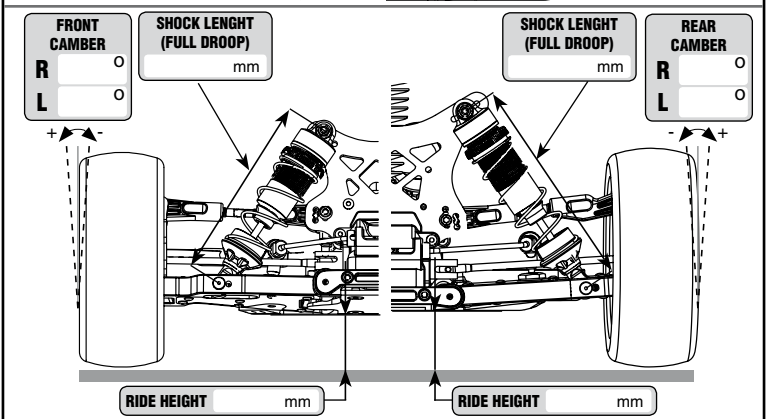
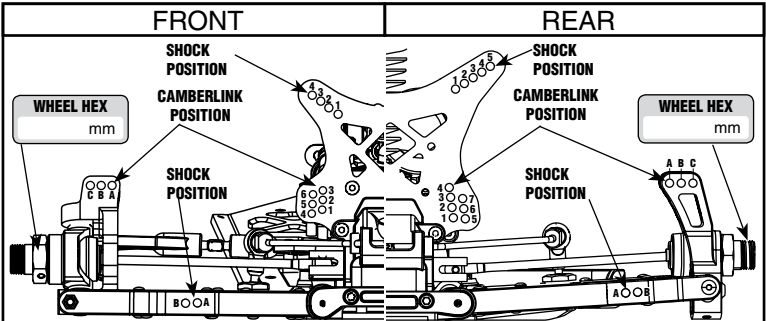

REMARKS