



RACE	AE Champs	DATE	2016	TRACK	Trackside
DRIVER	Paul Ciccarello	TRACK TEMP		AIR TEMP	
TRACK DESCRIPTION		<input checked="" type="checkbox"/> INDOOR	<input checked="" type="checkbox"/> TIGHT	<input type="checkbox"/> MEDIUM	<input type="checkbox"/> LOW BITE
		<input type="checkbox"/> OUTDOOR	<input type="checkbox"/> OPEN	<input type="checkbox"/>	<input checked="" type="checkbox"/> MED BITE
		<input checked="" type="checkbox"/> SMOOTH	<input type="checkbox"/> HARD PACKED	<input type="checkbox"/> GRASS	<input type="checkbox"/> ASTRO-TURF
		<input type="checkbox"/> ROUGH	<input type="checkbox"/> BLUE GROOVE	<input type="checkbox"/> CARPET	<input type="checkbox"/> MULTI/SURFACE
		<input checked="" type="checkbox"/> CLAY			

FRONT DIFFERENTIALS		REAR	
<input type="checkbox"/> BALL DIFFERENTIAL	<input checked="" type="checkbox"/> BALL DIFFERENTIAL	<input type="checkbox"/> BALL DIFFERENTIAL	<input checked="" type="checkbox"/> BALL DIFFERENTIAL
<input checked="" type="checkbox"/> GEAR DIFF 15000 cst	<input type="checkbox"/> GEAR DIFF 0 cst	<input type="checkbox"/> GEAR DIFF 0 cst	<input type="checkbox"/> GEAR DIFF 0 cst
<input type="checkbox"/> ONE WAY			
DIFFERENTIAL HEIGHT	DIFFERENTIAL HEIGHT	DIFFERENTIAL HEIGHT	DIFFERENTIAL HEIGHT
<input type="checkbox"/> HIGH <input checked="" type="checkbox"/> MED <input type="checkbox"/> LOW	<input type="checkbox"/> HIGH <input checked="" type="checkbox"/> MED <input type="checkbox"/> LOW	<input type="checkbox"/> HIGH <input checked="" type="checkbox"/> MED <input type="checkbox"/> LOW	<input type="checkbox"/> HIGH <input checked="" type="checkbox"/> MED <input type="checkbox"/> LOW

GEAR RATIO	
SPUR GEAR	TEETH 28/19
PINION	TEETH 76/82
FINAL DRIVE RATIO	

ELECTRONICS	
<b>BATTERY</b>	
BRAND	Motiv CAPACITY 4000
<b>MOTOR</b>	
BRAND	Motiv TYPE 13.5/5.5 TIMING 54/10
<b>ESC</b>	
BRAND	HW TYPE XR10 Pro

SHOCK ABSORBERS	
OIL	FRONT 450 cst REAR 375 cst
SPRING	blue pink astro
LIMITERS (2)	2 mm 2 mm
LENGTH (3)	87 mm 103 mm
REBOUND (4)	2 mm 2 mm
BLADDER / SEAL (5)	<input type="checkbox"/> BLADDER <input type="checkbox"/> BLADDER <input checked="" type="checkbox"/> SEAL <input checked="" type="checkbox"/> SEAL
SPRING BUCKET	<input type="checkbox"/> SHORT <input checked="" type="checkbox"/> SHORT <input checked="" type="checkbox"/> LONG <input type="checkbox"/> LONG
PISTONS (1)	N° OF HOLES 4 4
	DIAMETER 1.5x2 1.1x2 mm 1.6x2 1.1x2 mm
<b>TYPE</b>	
<input type="checkbox"/> STOCK <input type="checkbox"/> CONICAL <input checked="" type="checkbox"/> SQUARE	

FRONT <input type="checkbox"/> ANTI-ROLL BARS	REAR <input checked="" type="checkbox"/>
<input type="checkbox"/> 0.9 <input type="checkbox"/> 1 <input type="checkbox"/> 1.1 <input type="checkbox"/> Other	<input checked="" type="checkbox"/> 1.1 <input type="checkbox"/> 1.3 <input type="checkbox"/> 1.5 <input type="checkbox"/> Other

TIRES	
FRONT Controlled Tire <input type="checkbox"/>	REAR
JC MAKE	JC
DW TYPE	space bars
gold COMPOUND	Clay
JC INSERT TYPE	JC
serpent WHEELS	serpent
ADDITIVE	

AERODYNAMIC CONFIGURATION	
BODY BRAND	serpent TYPE
REAR WING BRAND	JC TYPE
REAR WING WIDTH	6.5
REAR WING LIP	10mm mm
REAR WING ANGLE	0 <input type="checkbox"/> 2 <input type="checkbox"/> 4 <input checked="" type="checkbox"/> 6 <input type="checkbox"/> 8 <input type="checkbox"/>
FRONT WING	YES <input type="checkbox"/> NO <input checked="" type="checkbox"/>

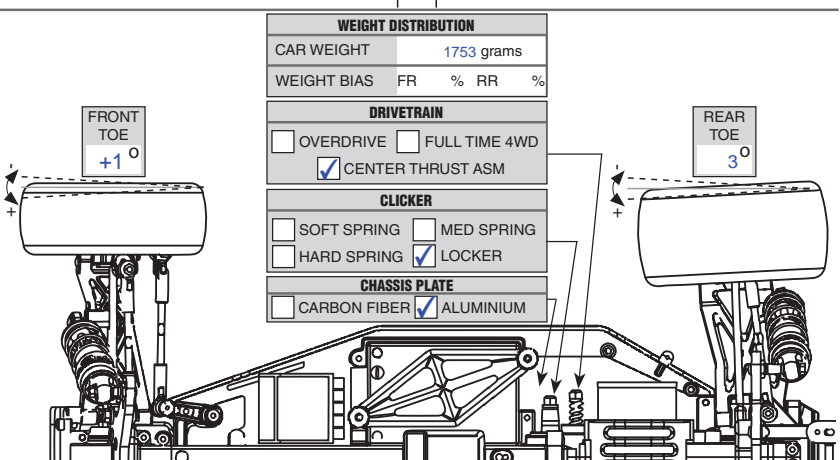
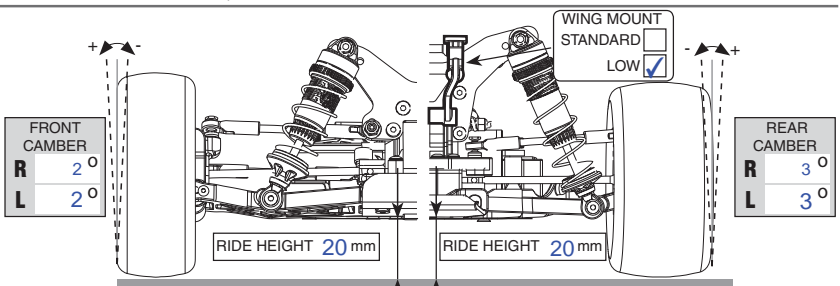
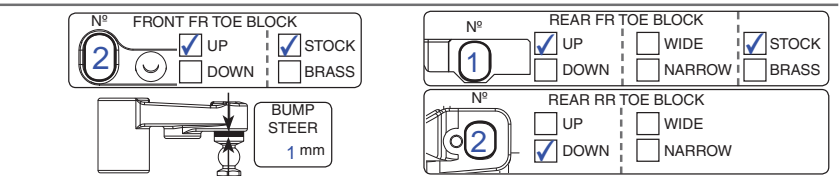
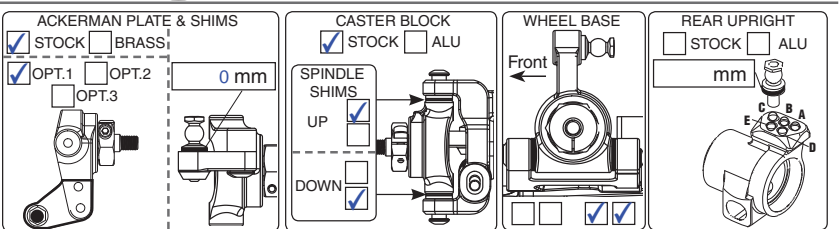
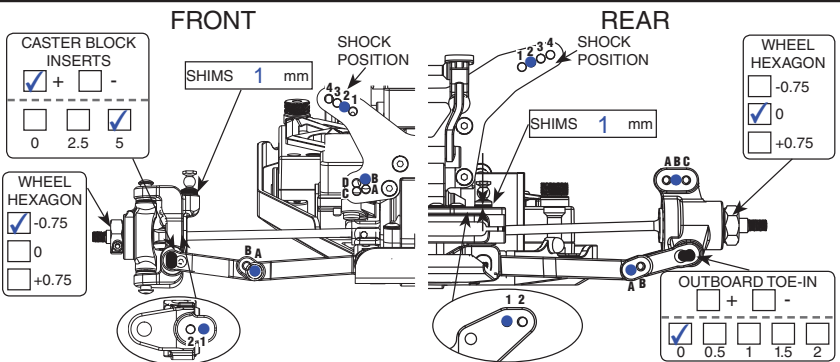

**REMARKS**

500114 rear hub, turn dual rate down 10-15% with std 1 ackerman for bigger tracks, shorty conversion, pistons 4 hole drilled 2 holes 1.5 front/ 2 holes 1.6 rear leave 2 holes stock, also try orange Ae spring for higher grip conditions or bigger tracks