



RACE DATE TRACK
 DRIVER TRACK TEMP AIR TEMP
 INDOOR TIGHT MEDIUM LOW BITE HIGH BITE
 OUTDOOR OPEN MED BITE
 TRACK DESCRIPTION
 SMOOTH HARD PACKED GRASS ASTRO-TURF CLAY
 ROUGH BLUE GROOVE CARPET MULTI/SURFACE

FRONT DIFFERENTIALS REAR
 BALL DIFFERENTIAL BALL DIFFERENTIAL
 GEAR DIFF cst GEAR DIFF cst
 ONE WAY
 DIFFERENTIAL HEIGHT DIFFERENTIAL HEIGHT
 HIGH MED LOW HIGH MED LOW

GEAR RATIO

SPUR GEAR	TEETH	19
PINION	TEETH	86
FINAL DRIVE RATIO		

ELECTRONICS

BATTERY
 BRAND CAPACITY

MOTOR
 BRAND TYPE TIMING

ESC
 BRAND TYPE

SHOCK ABSORBERS

	FRONT	REAR
OIL	550 cst	300 cst
SPRING	red	pink astro
LIMITERS (2)	2 mm	2 mm
LENGTH (3)	86.5 mm	103 mm
REBOUND (4)	2 mm	2 mm
BLADDER / SEAL (5)	<input type="checkbox"/> BLADDER <input checked="" type="checkbox"/> SEAL	<input type="checkbox"/> BLADDER <input checked="" type="checkbox"/> SEAL
SPRING BUCKET	<input type="checkbox"/> SHORT <input checked="" type="checkbox"/> LONG	<input type="checkbox"/> SHORT <input type="checkbox"/> LONG
PISTONS (1)	N° OF HOLES	2
	DIAMETER	1.6 mm
TYPE		
<input checked="" type="checkbox"/> STOCK <input type="checkbox"/> CONICAL <input type="checkbox"/> SQUARE		

FRONT ANTI-ROLL BARS **REAR**
 0.9 1 1.1 Other 1.1 1.3 1.5 Other

TIRES

FRONT	Controlled Tire	REAR
AKA	MAKE	AKA
chainlinks	TYPE	chainlinks
Clay	COMPOUND	Clay
dirt tech	INSERT TYPE	aka red
serpent	WHEELS	serpent
LW	ADDITIVE	LW

AERODYNAMIC CONFIGURATION

BODY BRAND TYPE

REAR WING BRAND TYPE

REAR WING WIDTH

REAR WING LIP mm

REAR WING ANGLE 0 2 4 6 8

FRONT WING YES NO

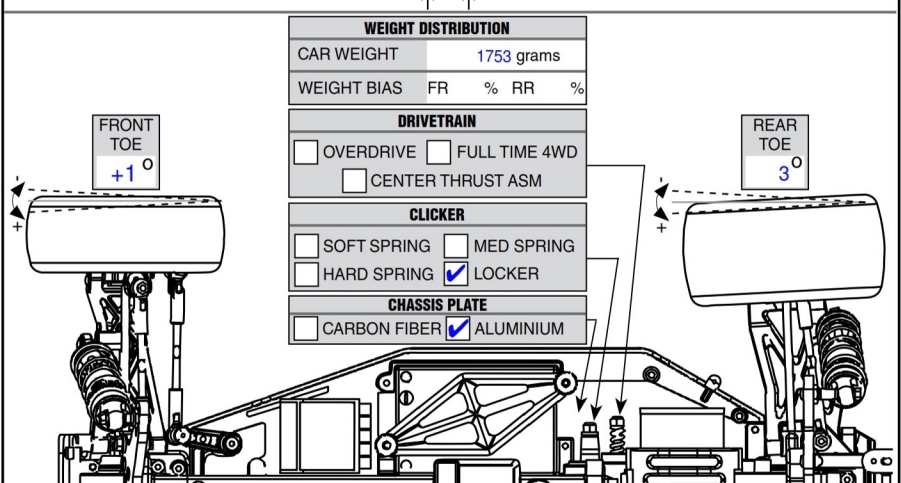
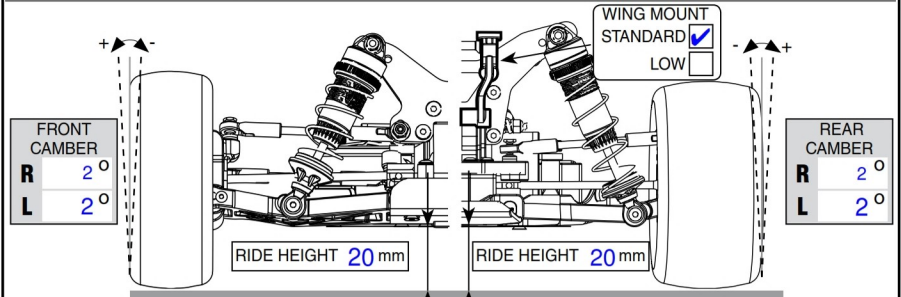
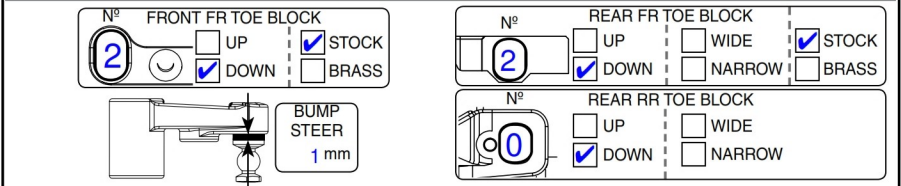
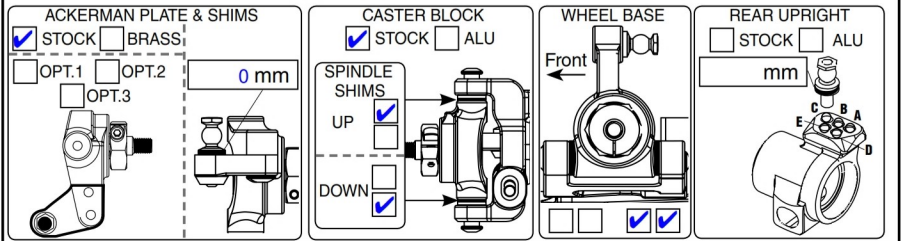
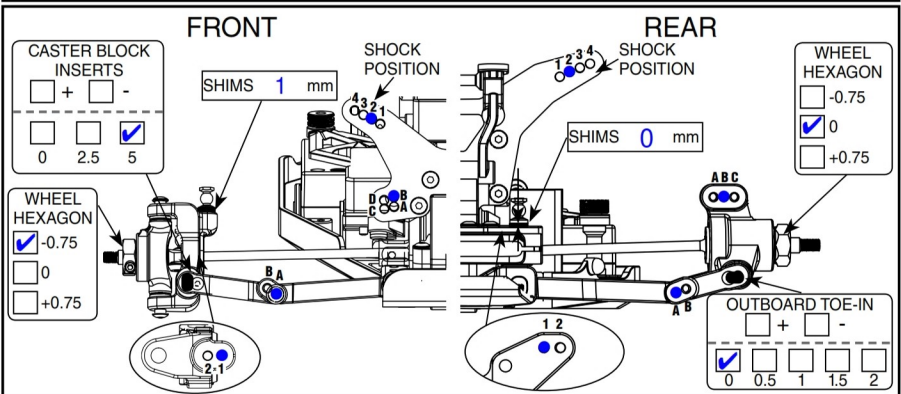

REMARKS
 500114 rear hubs, -1 ackerman from RC Shox, Diff inserts from CR Lovell to loosen the front belt. Changes for 13.5 401353 side belt, carbon chassis, shorty conversion, red astro rear sping, 28-78 gearing