

SET UP



REAR DIFFERENTIAL	
<input type="checkbox"/> BALL DIFFERENTIAL	DIFFERENTIAL HEIGHT
<input type="checkbox"/> GEAR DIFF	cst <input type="checkbox"/> HIGH <input type="checkbox"/> MED <input type="checkbox"/> LOW

GEAR RATIO	
SPUR GEAR	TEETH
PINION	TEETH
FINAL DRIVE RATIO	

ELECTRONICS		
BATTERY:	SADDLE <input type="checkbox"/>	SHORTY <input type="checkbox"/>
BRAND	CAPACITY	
MOTOR		
BRAND	TYPE	TIMING
ESC		
BRAND	TYPE	

SHOCK ABSORBERS			
		FRONT	REAR
OIL	(5)	cst	cst
SPRING			
LIMITERS (2)	(1)	mm	mm
LENGTH (3)	(2)	mm	mm
REBOUND (4)	(3)	mm	mm
BLADDER / SEAL (5)	(4)	<input type="checkbox"/> BLADDER <input type="checkbox"/> BLADDER <input type="checkbox"/> SEAL <input type="checkbox"/> SEAL	
SPRING BUCKET		<input type="checkbox"/> SHORT <input type="checkbox"/> SHORT <input type="checkbox"/> LONG <input type="checkbox"/> LONG	
PISTONS (1)	N° OF HOLES		
	DIAMETER	mm	mm
		TYPE	
		<input type="checkbox"/> STOCK	<input type="checkbox"/> CONICAL <input type="checkbox"/> SQUARE

FRONT	ANTI-ROLL BARS	REAR
<input type="checkbox"/> 0.9 <input type="checkbox"/> 1 <input type="checkbox"/> 1.1 <input type="checkbox"/> Other	<input type="checkbox"/> 1.1 <input type="checkbox"/> 1.3 <input type="checkbox"/> 1.5 <input type="checkbox"/> Other	

TIRES		
FRONT	Controlled Tire <input type="checkbox"/>	REAR
	MAKE	
	TYPE	
	COMPOUND	
	INSERT TYPE	
	WHEELS	
	ADDITIVE	

AERODYNAMIC CONFIGURATION		
BODY	BRAND	TYPE
REAR WING	BRAND	TYPE
REAR WING WIDTH		
REAR WING LIP		
mm		
REAR WING ANGLE	0 <input type="checkbox"/> 2 <input type="checkbox"/> 4 <input type="checkbox"/> 6 <input type="checkbox"/> 8 <input type="checkbox"/>	
FRONT WING	YES <input type="checkbox"/> NO <input type="checkbox"/>	

RACE	DATE	TRACK
DRIVER	TRACK TEMP	AIR TEMP
<input type="checkbox"/> INDOOR <input type="checkbox"/> TIGHT <input type="checkbox"/> MEDIUM <input type="checkbox"/> LOW BITE <input type="checkbox"/> HIGH BITE <input type="checkbox"/> OUTDOOR <input type="checkbox"/> OPEN <input type="checkbox"/> <input type="checkbox"/> MED BITE <input type="checkbox"/> <input type="checkbox"/>		
TRACK DESCRIPTION		
<input type="checkbox"/> SMOOTH <input type="checkbox"/> HARD PACKED <input type="checkbox"/> GRASS <input type="checkbox"/> ASTRO-TURF <input type="checkbox"/> CLAY <input type="checkbox"/> ROUGH <input type="checkbox"/> BLUE GROOVE <input type="checkbox"/> CARPET <input type="checkbox"/> MULTI/SURFACE <input type="checkbox"/>		

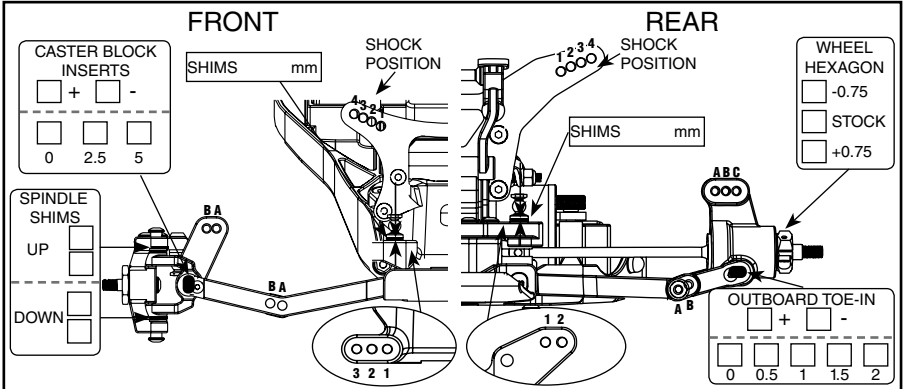

FRONT BULKHEAD <input type="checkbox"/> STOCK <input type="checkbox"/> ALU <input type="checkbox"/> BRASS INSERT <input type="checkbox"/> 20° <input type="checkbox"/> 25° <input type="checkbox"/> 30°	FRONT CASTER BLOCK <input type="checkbox"/> STOCK <input type="checkbox"/> ALU mm	WHEEL BASE Front	REAR UPRIGHT <input type="checkbox"/> STOCK <input type="checkbox"/> ALUMINUM mm
--	---	---------------------	--

BUMP STEER mm	ACKERMAN PLATE <input type="checkbox"/> STOCK <input type="checkbox"/> BRASS OPT.1 OPT.2 OPT.3	N° REAR FR TOE BLOCK <input type="checkbox"/> UP <input type="checkbox"/> WIDE <input type="checkbox"/> STOCK <input type="checkbox"/> DOWN <input type="checkbox"/> NARROW <input type="checkbox"/> BRASS	N° REAR RR TOE BLOCK <input type="checkbox"/> UP <input type="checkbox"/> WIDE <input type="checkbox"/> DOWN <input type="checkbox"/> NARROW
------------------	--	--	--

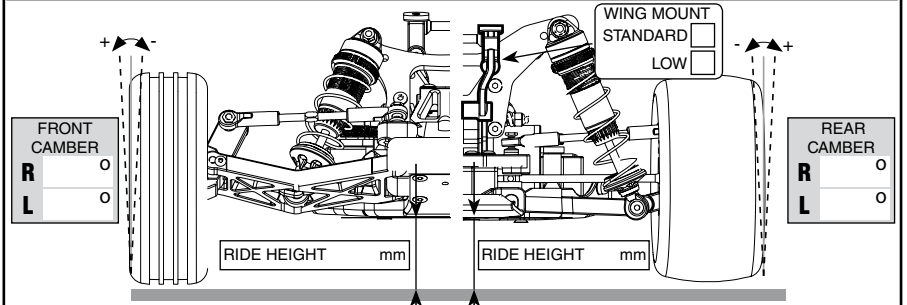

FRONT TOE	0	REAR TOE	0
WEIGHT DISTRIBUTION			
CAR WEIGHT		grams	
WEIGHT BIAS	FR	%	RR %
BATTERY LOCATION		mm	
BALLAST WEIGHT			
<input type="checkbox"/> YES <input type="checkbox"/> NO			

REMARKS	