

SET UP



RACE **OHKY Round 5** DATE **2015-02-07** TRACK **Batavia RC, Ohio, USA**

DRIVER **Dylan Gerard** TRACK TEMP AIR TEMP

INDOOR TIGHT MEDIUM LOW BITE HIGH BITE
 OUTDOOR OPEN MED BITE

TRACK DESCRIPTION

SMOOTH HARD PACKED GRASS ASTRO-TURF CLAY
 ROUGH BLUE GROOVE CARPET MULTI/SURFACE Top Soil

REAR DIFFERENTIAL

BALL DIFFERENTIAL DIFFERENTIAL HEIGHT
 GEAR DIFF cst HIGH MED LOW

GEAR RATIO

SPUR GEAR	TEETH	78
PINION	TEETH	21
FINAL DRIVE RATIO		

ELECTRONICS

BATTERY: SADDLE SHORTY
 BRAND **SMC** CAPACITY **4600**
MOTOR
 BRAND **Tekin** TYPE **7.5** TIMING
ESC
 BRAND **Tekin** TYPE **RSX**

SHOCK ABSORBERS

OIL	PT 550 cst	PT 325 cst	
SPRING	black	pink	
LIMITERS (2)	2 mm	2 mm	
LENGTH (3)	86.5 mm	103 mm	
REBOUND (4)	1 mm	1 mm	
BLADDER / SEAL (5)	<input checked="" type="checkbox"/> BLADDER <input checked="" type="checkbox"/> SEAL	<input type="checkbox"/> BLADDER <input checked="" type="checkbox"/> SEAL	
SPRING BUCKET	<input checked="" type="checkbox"/> SHORT <input checked="" type="checkbox"/> LONG	<input type="checkbox"/> SHORT <input type="checkbox"/> LONG	
PISTONS (1)	N° OF HOLES	2	2
	DIAMETER	1.7 mm	1.6 mm
TYPE			
<input checked="" type="checkbox"/> STOCK <input type="checkbox"/> CONICAL <input type="checkbox"/> SQUARE			

FRONT ANTI-ROLL BARS **REAR**
 Other Other
 0.9 1 1.1 1.1 1.3 1.5

TIRES

FRONT	Controlled Tire <input type="checkbox"/>	REAR
AKA	MAKE	AKA
Handlebar	TYPE	Chainlink
Super Soft	COMPOUND	Super Soft
AKA	INSERT TYPE	AKA
AKA 2.4 EVO	WHEELS	AKA 2.2 Hexlight
---	ADDITIVE	---

AERODYNAMIC CONFIGURATION

BODY BRAND **JC** TYPE **Silencer**
REAR WING BRAND **JC** TYPE **High Clearance**
REAR WING WIDTH **6.5** inch
REAR WING LIP **cut on line 2 from the bottom** mm
REAR WING ANGLE 0 2 4 6 8
FRONT WING YES NO

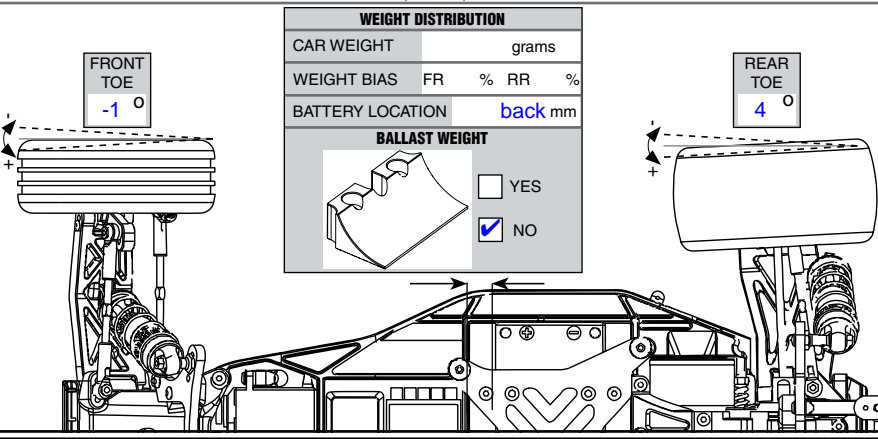
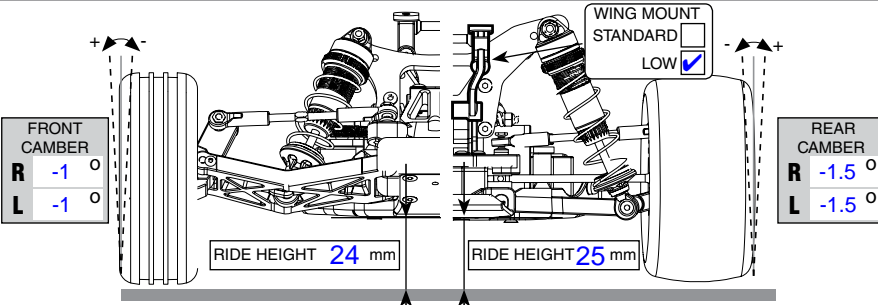
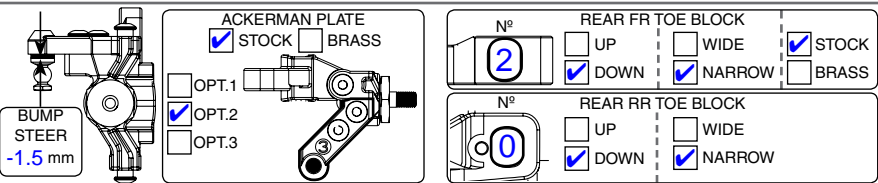
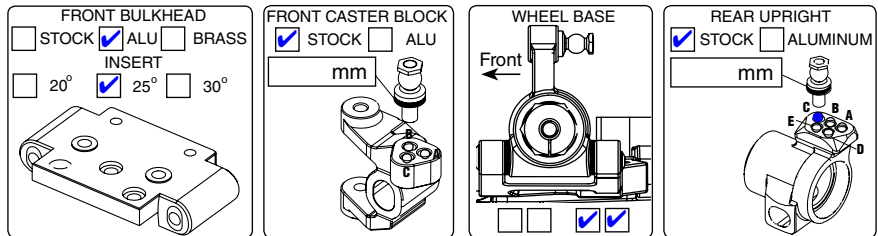
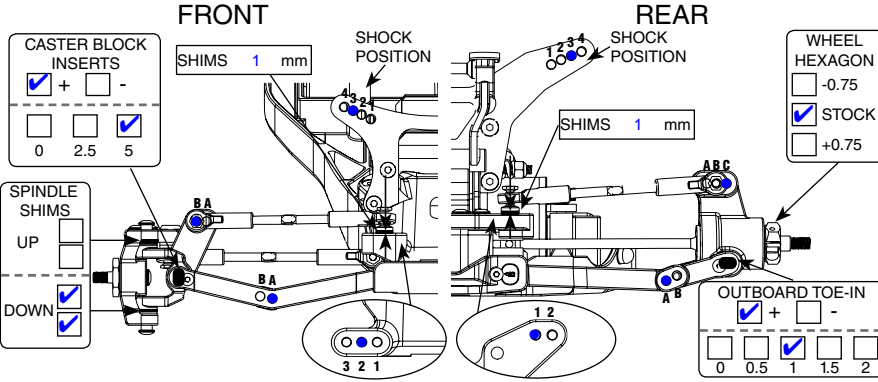

REMARKS

TQ and first, Ball Diff Medium Tight. Low Profile Servo.