

**DRIVER, TRACK & RESULTS**

Driver *Kyle Gannon* Country \_\_\_\_\_ Weather Air Temperature  Dry  Intermediate  Wet

Race *Ae Champs* Date *10-18-2017* Qualification *TQ* Final *4th*

Track  Indoor  Outdoor  Tight  Mixed  Open  Smooth  Rough  Low  Medium  High

Condition  Astroturf  Carpet  Clay  Dirt  Grass  Multisurface  Blue-Groove  Hard Packed

**Front SHOCK ABSORBERS Rear**

350 Oil 300

*Ae White* Springs *Yok Green*

Rebound

87mm Limiters 101mm

1.4 3 hole Pistons 1.7 2 hole

Stock  Square  Stock  Square

Conical V  Conical A  Conical V  Conical A

Short  Long Spring Buckets  Short  Long

Bladder  Emulsion Seal Type  Bladder  Emulsion

**ANTI-ROLL BARS**

0.9  1  1.1  1.3  1.5 mm

**TIRES** Controlled

*J Concepts Space Bar* Tire *J Concepts Space Bar*

*Clay* Compound *Clay*

*stock* Inserts *stock*

*Serpent* Wheels *Serpent*

Additive

*Sticky Situation tire sauce.* Notes *Tires treated with Sticky Situation Pre-soak*

**Differential**

Ball Diff  Gear Diff

Differential Height  High  Middle  Low  Fixed

**Gearing**

Pinion *27* T Spur *75* T

**Electronics**

**Battery**  
*Motiv shorty*

**Motor**  
*Motiv MC2*

**ESC**  
*Hobbywing XR-10 pro stock spec*

**Aerodynamics**

Body *light*

Wing *J Concepts* Lip \_\_\_\_\_ mm

Wing Angle  0°  2°  4°  6°  8°

Front Wing *75J Concepts*

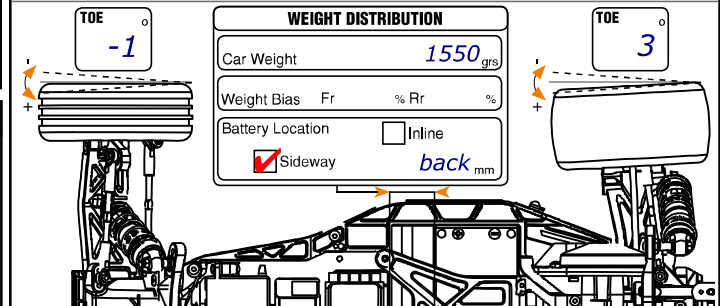
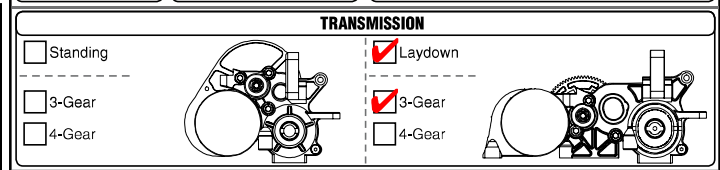
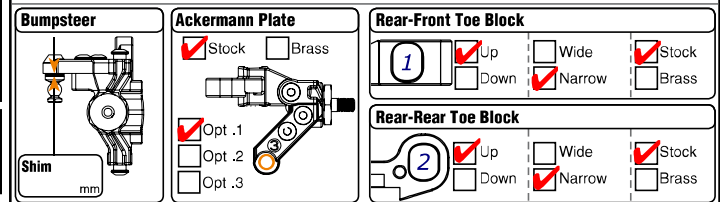
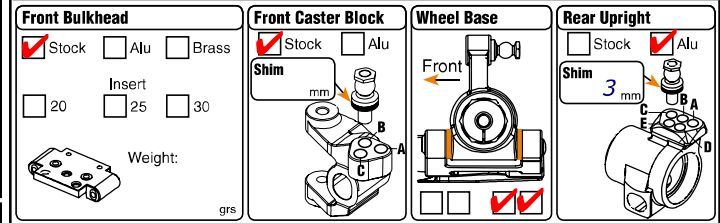
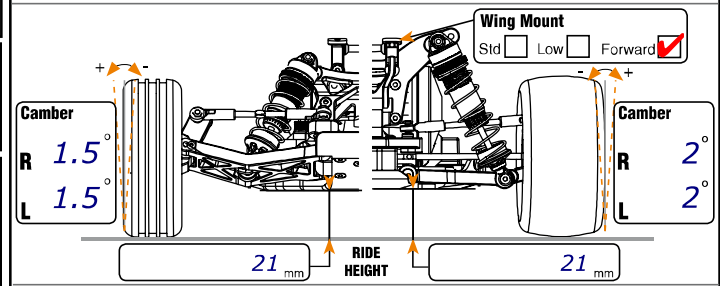
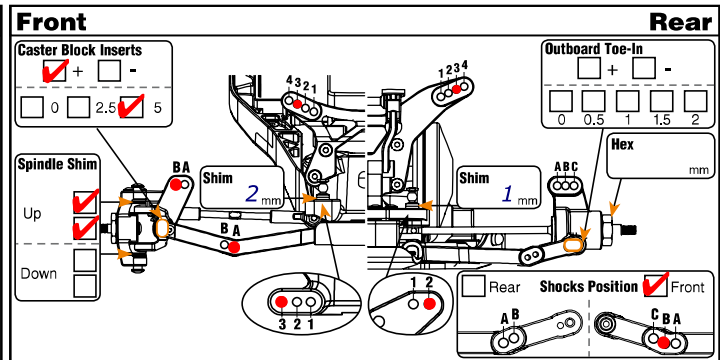

Schelle rear hubs with 67mm axle conversion. 5mm J Concepts rear hex. Outer camber hole on hubs shimmed in 2mm. 3mm of outer camber link shim. Stock front suspension. No upper holes on waterfall. Long rear arms. Ackerman plates shimmed up 1mm.