

Driver and Event	
Name	
Date	
Event	
Weather	
Result	

Track Conditions	
Surface	
Grip Level	
Track Condition	

Driver Notes	

Electrics and Gearing	
E.S.C	
Servo	
Receiver	
Batteries	
Motor	
Spur	Pinion
Ext Gears	34/22
	33/23
	32/24

Wheels and Tyres	
Rear Wheels	
Rear Tyre	
Rear Insert	
Front Wheels	
Front Tyre	
Front Insert	

Differential Height	
High	Low

Topdeck		
Stiff	Medium	Soft

Rear Shocks	
Oil	Spring
Piston Holes	2 3 4 5 6
Shock Length	



Front Shocks	
Oil	Spring
Piston Holes	2 3 4 5 6
Shock Length	

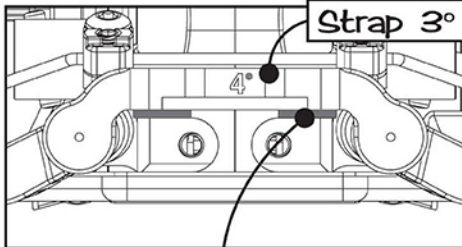
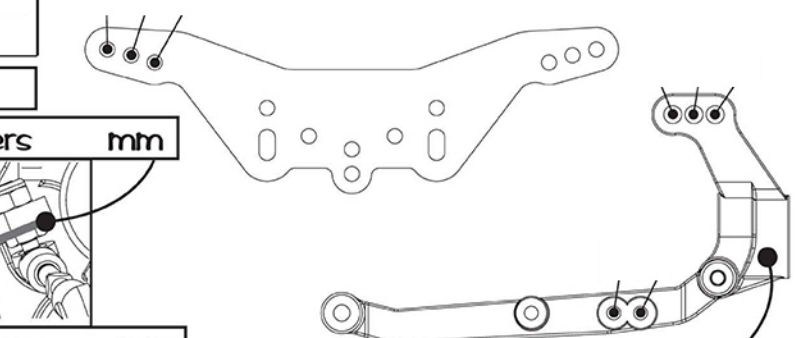

Rear Suspension	
Anti roll bar	No 1.20 1.40 1.60
Strap	3° 4° 5°
Antisquat Washers	mm
Link Washers	mm
Shock Postion	Front Rear
Wheelbase	Short Med Long
Rear Camber at Ride Height	

Rear Hub Carrier	Alloy	Std
Alloy Hub Carrier	+1°	-1°
49 44 39 34		

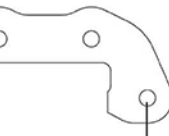

Front Suspension	
Link Washers	mm
Front Camber at Ride Height	
Front Toe In	

Yoke	0° 5°
Hub Carrier	High Low
50.5 45.5 40.5	

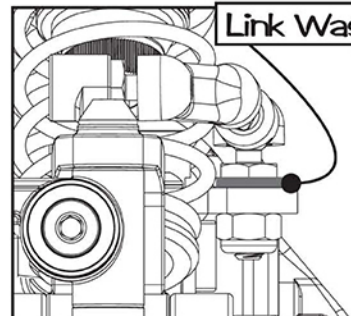
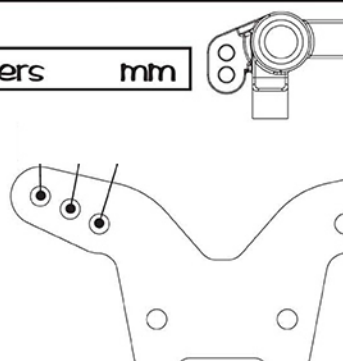
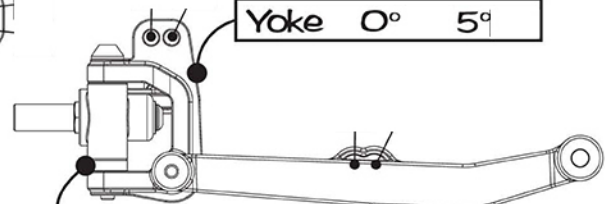
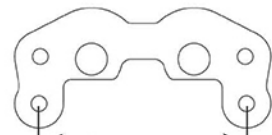
Editable by Am0@PetitRC.com