

Driver and Event

Name _____

Date _____

Event _____

Weather _____

Result _____

Track Conditions

Surface _____

Grip Level _____

Track Condition _____



Driver Notes

Electrics and Gearing

E.S.C _____

Servo _____

Receiver _____

Batteries _____

Motor _____

Spur _____ Pinion _____

Ext Gears 34/22

33/23

32/24

Wheels and Tyres

Rear Wheels _____

Rear Tyre _____

Rear Insert _____

Front Wheels _____

Front Tyre _____

Front Insert _____

Differential Height

High Low

Topdeck

Stiff Medium Soft

Rear Shocks

Oil _____ Spring _____

Ball Short

Socket Long

Piston Holes 2 3 4 5 6

Front Shocks

Oil _____ Spring _____

Piston Holes 2 3 4 5 6

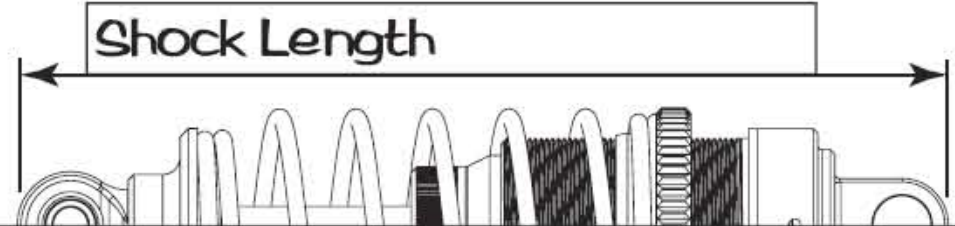
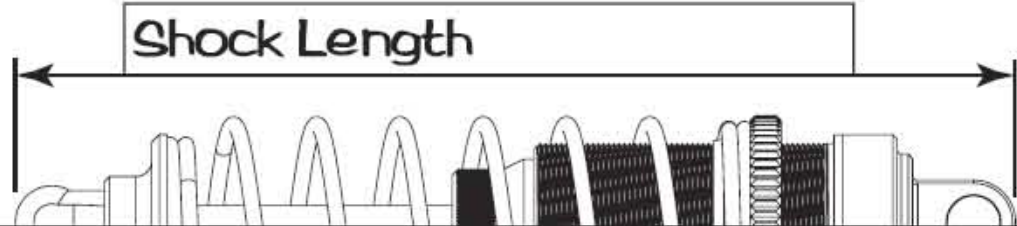

Rear Suspension

Anti roll bar No 1.20 1.40 1.60

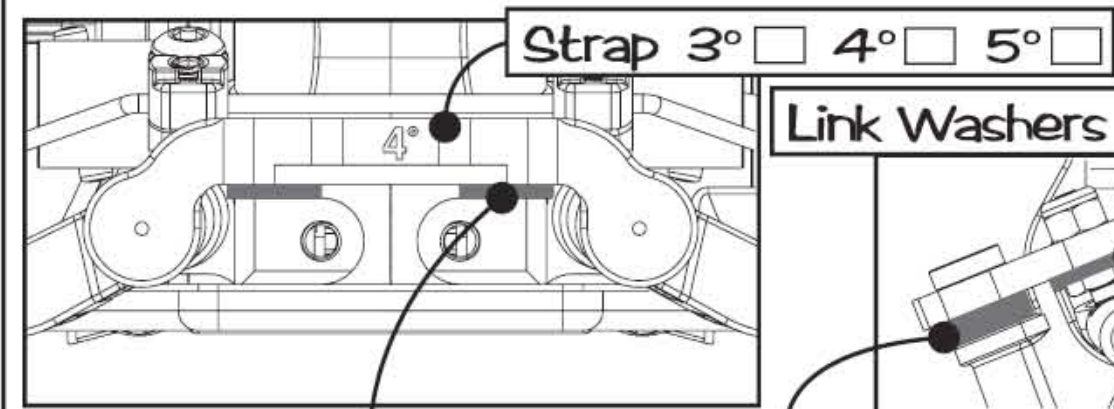

Antisquat Washers _____ mm

Shock Postion Front Rear

Wheelbase Short Med Long

Rear Camber at Ride Height _____

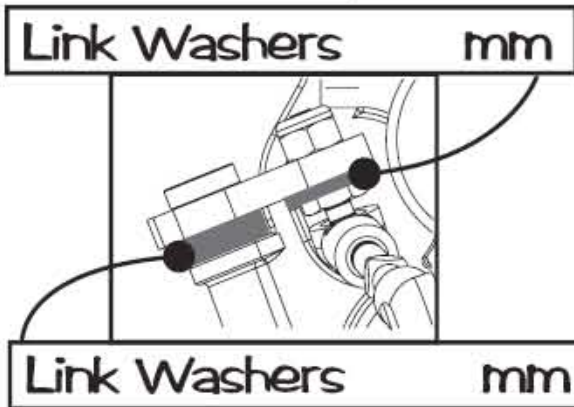

Link Washers _____ mm

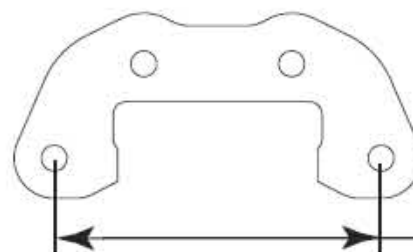

Rear Hub Carrier Alloy Std

Alloy Hub Carrier +1° -1°

49 44 39 34

Front Suspension

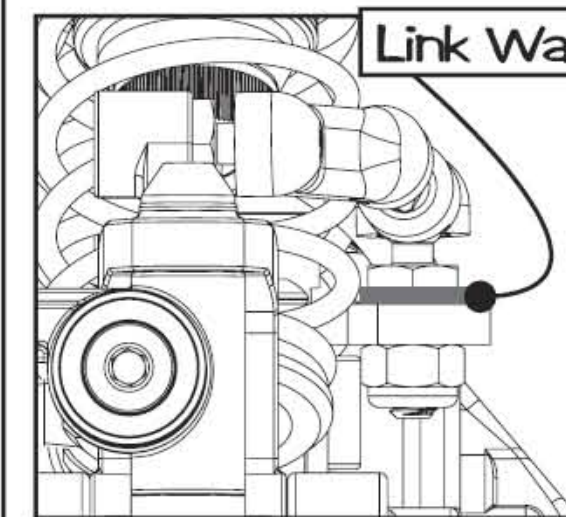

Front Camber at Ride Height _____

Front Toe In _____

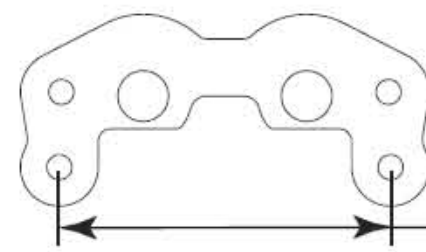
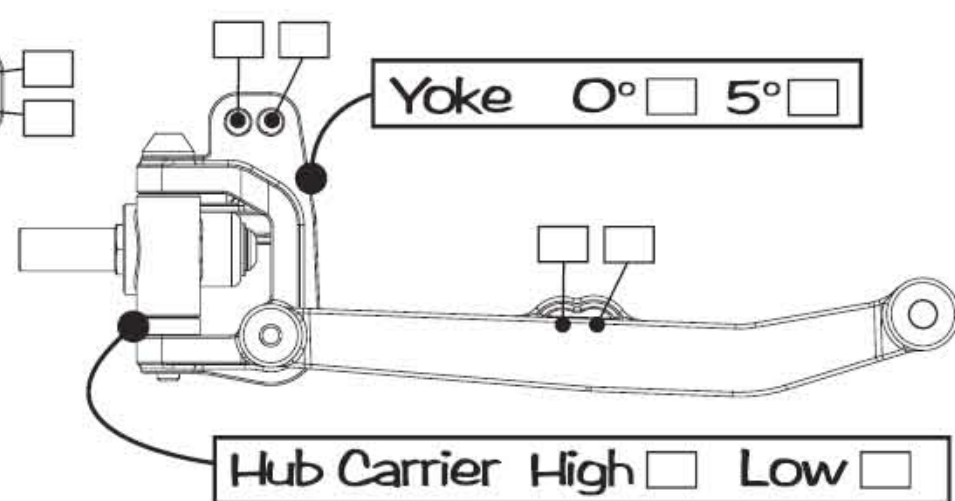
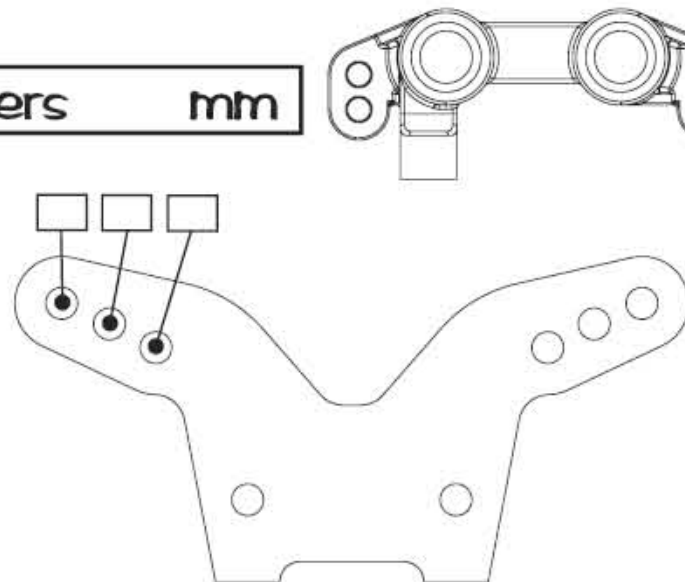

50.5 45.5 40.5