

SET UP SHEET



Driver: Ben Smith Date: 03/07/2021 Event/Track: Telford SOOM
 Qualify: Q4 F3 Final: A Final Best Lap: 24.31

TRACK TYPE

Grip Level High Medium Low
 Type Tight Open Mixed
 Condition Flat Bumpy Mixed
 Surface Clay Long Astro Carpet
 Grass Short Astro Mixed
 Weather Wet and greasy moving to Dry

TYRES

	FRONT	REAR
Tyres	Silver Cut Stagger Ribs	Silver Mezzo
Wheels	Kit	Kit
Inserts	None	Tubby

Notes:
 Yellow Mezzo with Tubby inserts with yellow cut staggerers in the dry, 3 toe in the dry.

Notes:

Track dried by the finals, Flipped the rear arms for the Wet and Flipped back for the Dry.

FRONT SUSPENSION

KEY: P = Plastic, A = Alloy, B = Brass, CF = Carbon Fibre, S2 = Schumacher Composite, M = Medium, S = Stiff, Sh = Short, H = High, L = Low, F = Front, R = Rear, Y = Yes, N = No

Ride Height mm
 Wheelbase +1.5 +3.0 +4.5
 Toe deg In Out
 Camber at Ride Height deg
 Anti Roll Bar 1.0 1.1 1.2
 Front Wing Y N
 Hub Height H M L
 Bump Steer Washers mm
 Pivot Block Height H M L

Notes:

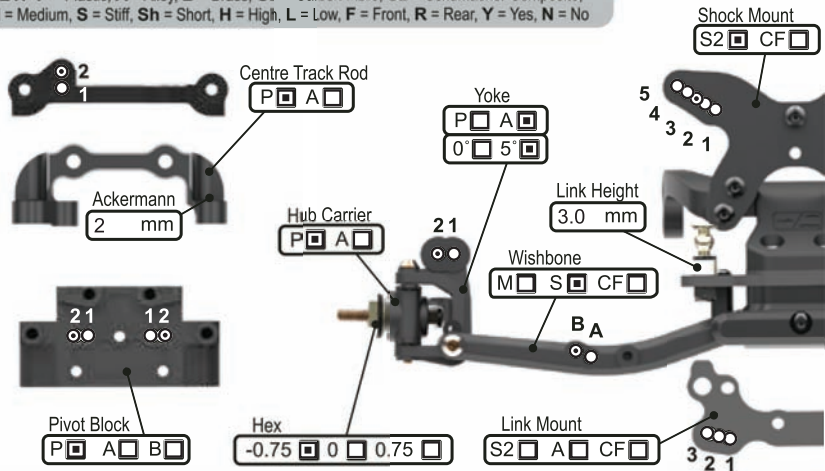

REAR SUSPENSION

KEY: P = Plastic, A = Alloy, B = Brass, CF = Carbon Fibre, S2 = Schumacher Composite, M = Medium, S = Stiff, Sh = Short, H = High, L = Low, F = Front, R = Rear, Y = Yes, N = No

Ride Height mm
 Wheelbase Sh M L
 Anti-Squat 2 3 4
 Toe 3.5 3 2.5 2 1.5 1.0 0.5
 Camber at Ride Height deg
 Anti Roll Bar 1.1 1.2 1.3 1.4
 Wing Gurney Height mm
 Rearward Shock Position Only A B
 Driveshaft Type CVD U/J

Notes:

Flipped rear arms hub in Long wheel base position.
 When It dried moved to the normal Rear arm position

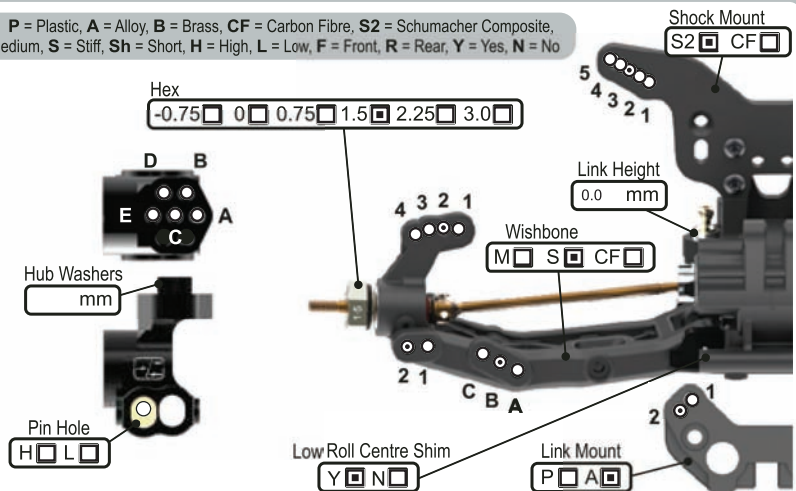

TRANSMISSION

Diff Height H M L
 Diff Oil
 Diff Type B 2g 4g
 Motor
 Rotor Dia. mm
 Timing deg
 Pinion t
 Spur t
 Motor Plate A CF
 Lock Out Y N
 Slipper Plates 2 3

CHASSIS

Chassis A C/F
 Side Pods S C/F
 Chassis Insert 0mm +5mm
 LiPo Position 1 2 3 4 5 6 7 8
 X Brace Y N
 Running Weight
 Radio Tray 1 2 3
 Notes:
 30 Gram Lipo Weight,
 Esc on Blinky, 1 on throttle rate.

EQUIPMENT

E.S.C.
 Servo
 RX
 LiPo
 Bodyshell

WEIGHTS

Chassis F R
 Rear Strap F R
 Radio Tray Y N
 Under LiPo Y N

SHOCKS

KEY: i = Internal, e = External, V = Vented, S = Sealed, A = Aeration

	FRONT	REAR
Cap	<input type="checkbox"/> V <input type="checkbox"/> S <input type="checkbox"/> A <input type="checkbox"/>	<input type="checkbox"/> V <input type="checkbox"/> S <input type="checkbox"/> A <input type="checkbox"/>
Body	kit	kit
Oil	450 cSt	350 cSt
Piston	2 hole 1.8	2 hole 2.1
Spring	Blue lb/in	Green lb/in
Limiters (i)	0.0 mm	0.0 mm
Stroke	22.2 mm	28.5 mm
Limiters (e)	0.0 mm	0.0 mm

Notes:

