

Driver and Event	
Name	
Date	
Event	
Weather	
Result	

Track Conditions	
Surface	
Grip Level	
Track Condition	

Additional Settings	
Car Weight	
Washers between CTR and Bellcranks	mm
Chassis Alloy	<input type="checkbox"/>
Carbon	<input type="checkbox"/>

Electrics and Gearing	
E.S.C	
Servo	
Receiver	
Batteries	
Motor	
Spur	
Pinion	
Cell Position	

Wheels and Tyres	
Rear Wheels	
Rear Tyre	
Rear Insert	
Front Wheels	
Front Tyre	
Front Insert	

NOTES

Diff Type	
Ball	<input type="checkbox"/>
Gear	<input type="checkbox"/>
Diff Oil	

Front Shocks	
Oil	Spring
Shock Cap Sealed	<input type="checkbox"/>
Vented	<input type="checkbox"/>
Emulsion	<input type="checkbox"/>
Piston	
Drilled	<input type="checkbox"/>
Hole Size	mm
Shock Length	mm



Rear Shocks	
Oil	Spring
Shock Cap Sealed	<input type="checkbox"/>
Vented	<input type="checkbox"/>
Emulsion	<input type="checkbox"/>
Piston	
Drilled	<input type="checkbox"/>
Hole Size	mm
Shock Length	mm



Front Suspension	
Link Washers	mm
Yoke	0° <input type="checkbox"/> 5° <input type="checkbox"/> Alloy <input type="checkbox"/>
Hub Carrier	High <input type="checkbox"/> Middle <input type="checkbox"/> Low <input type="checkbox"/>
Front Ride Height	mm
Front Camber at Ride Height	Deg
Front Toe In	Deg
60.0	<input type="checkbox"/>
50.5	<input type="checkbox"/>
45.5	<input type="checkbox"/>
40.5	<input type="checkbox"/>

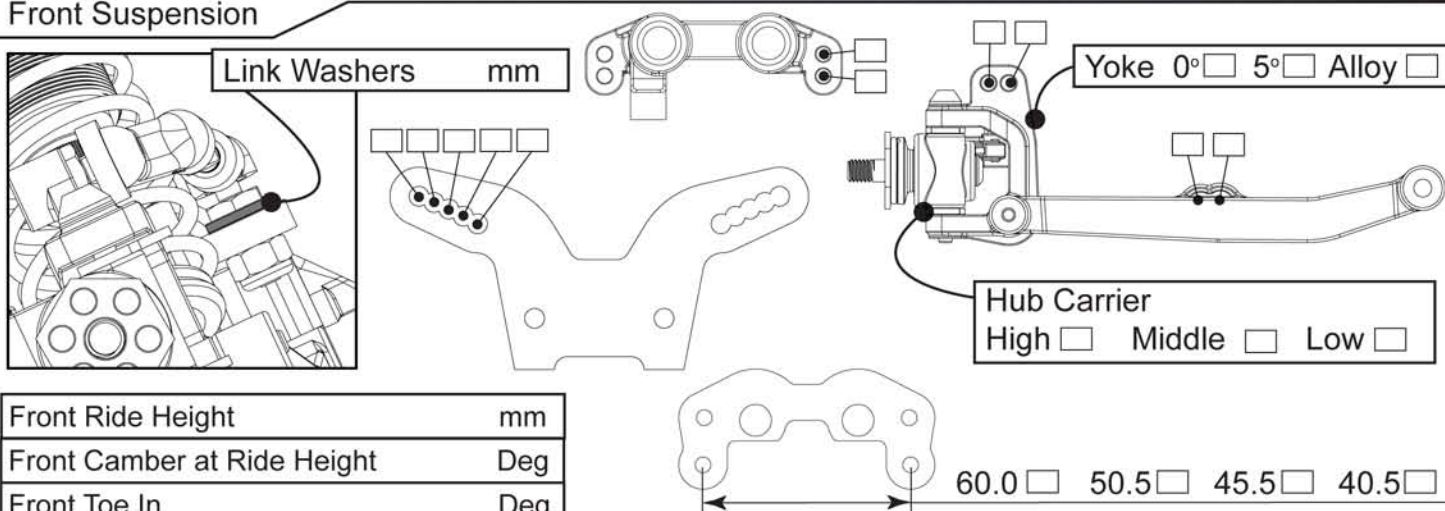

Rear Suspension	
Anti roll bar	No <input type="checkbox"/> 1.20 <input type="checkbox"/> 1.40 <input type="checkbox"/> 1.60 <input type="checkbox"/>
Toe-In	2° <input type="checkbox"/> 3° <input type="checkbox"/>
Link Washers	mm
AntiSquat	3° <input type="checkbox"/> 2° <input type="checkbox"/> 1° <input type="checkbox"/> 0° <input type="checkbox"/>
Wheelbase	Short <input type="checkbox"/> Med <input type="checkbox"/> Long <input type="checkbox"/>
Rear Ride Height	mm
Rear Camber at Ride Height	Deg
Rear Hub Carrier	Alloy <input type="checkbox"/> Std <input type="checkbox"/>
Alloy Hub Carrier	+1° <input type="checkbox"/> -1° <input type="checkbox"/>
49	<input type="checkbox"/>
44	<input type="checkbox"/>
39	<input type="checkbox"/>
34	<input type="checkbox"/>

