

Driver and Event	
Name	
Date	
Event	
Weather	
Result	

Track Conditions	
Surface	
Grip Level	
Track Condition	

Additional Settings	
Car Weight	
Washers between CTR and Bellcranks	mm
Chassis Alloy	<input type="checkbox"/>
Carbon	<input type="checkbox"/>

Electrics and Gearing	
E.S.C	
Servo	
Receiver	
Batteries	
Motor	
Spur	
Pinion	
Cell Position	

Wheels and Tyres	
Rear Wheels	
Rear Tyre	
Rear Insert	
Front Wheels	
Front Tyre	
Front Insert	

NOTES
-------

Diff Type	
Ball	<input type="checkbox"/>
Gear	<input type="checkbox"/>
Diff Oil	

Front Shocks	
Oil	Spring
Shock Cap Sealed	<input type="checkbox"/>
Vented	<input type="checkbox"/>
Emulsion	<input type="checkbox"/>
Piston	
Drilled	<input type="checkbox"/>
Hole Size	mm
Shock Length	mm



Rear Shocks	
Oil	Spring
Shock Cap Sealed	<input type="checkbox"/>
Vented	<input type="checkbox"/>
Emulsion	<input type="checkbox"/>
Piston	
Drilled	<input type="checkbox"/>
Hole Size	mm
Shock Length	mm



Front Suspension	
Link Washers	mm
Yoke	0° <input type="checkbox"/> 5° <input type="checkbox"/> Alloy <input type="checkbox"/>
Hub Carrier	High <input type="checkbox"/> Middle <input type="checkbox"/> Low <input type="checkbox"/>
Front Ride Height	mm
Front Camber at Ride Height	Deg
Front Toe In	Deg
60.0	<input type="checkbox"/>
50.5	<input type="checkbox"/>
45.5	<input type="checkbox"/>
40.5	<input type="checkbox"/>

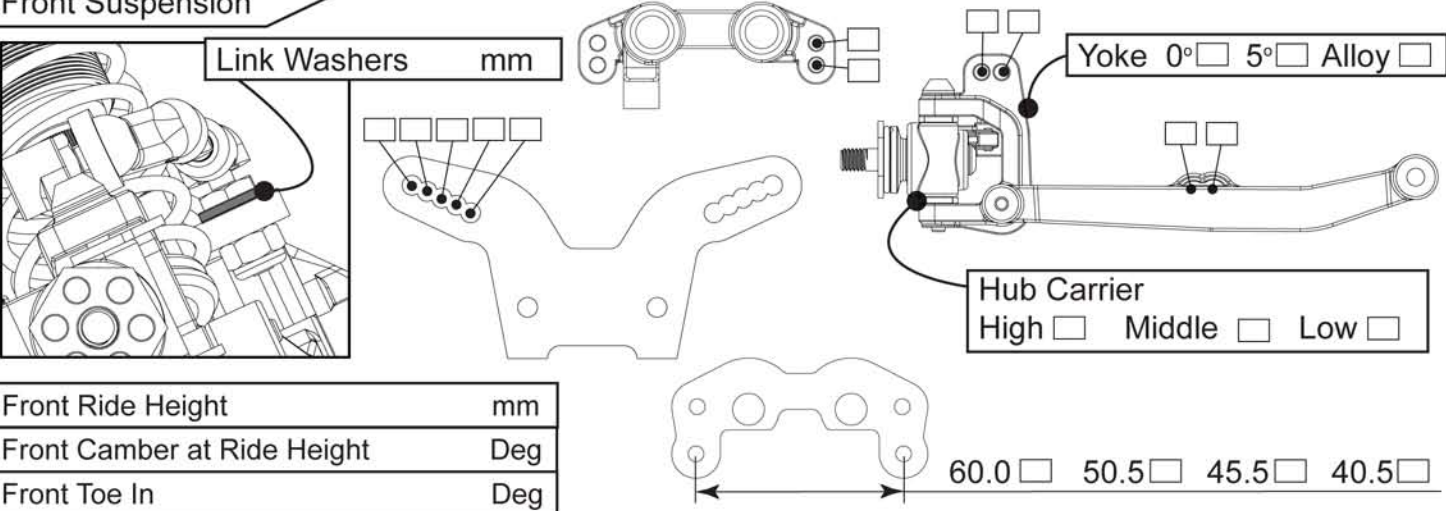

Rear Suspension	
Anti roll bar	No <input type="checkbox"/> 1.20 <input type="checkbox"/> 1.40 <input type="checkbox"/> 1.60 <input type="checkbox"/>
Toe-In	2° <input type="checkbox"/> 3° <input type="checkbox"/>
Link Washers	mm
AntiSquat	3° <input type="checkbox"/> 2° <input type="checkbox"/> 1° <input type="checkbox"/> 0° <input type="checkbox"/>
Wheelbase	Short <input type="checkbox"/> Med <input type="checkbox"/> Long <input type="checkbox"/>
Rear Ride Height	mm
Rear Camber at Ride Height	Deg
Rear Hub Carrier	Alloy <input type="checkbox"/> Std <input type="checkbox"/>
Alloy Hub Carrier	+1° <input type="checkbox"/> -1° <input type="checkbox"/>
49	<input type="checkbox"/>
44	<input type="checkbox"/>
39	<input type="checkbox"/>
34	<input type="checkbox"/>

