

Driver and Event	
Name	
Date	
Event	
Weather	
Result	

Track Conditions	
Surface	
Grip Level	
Track Condition	

Additional Settings	
Car Weight	
Washers Between	
CTR and Bellcranks	mm
Bump Steer Washers	mm
Wing Gurney Height	mm

Electrics and Gearing	
E.S.C	
Servo	
Receiver	
Batteries	
Motor	
Spur	
Pinion	
Side Gears	<input type="checkbox"/> 23T/33T Kit <input type="checkbox"/> <input type="checkbox"/> 21T/35T <input type="checkbox"/> <input type="checkbox"/> 25T/31T <input type="checkbox"/>

Wheels and Tyres	
Rear Wheels	
Rear Tyre	
Rear Insert	
Front Wheels	
Front Tyre	
Front Insert	

Diff Type	
Ball <input type="checkbox"/>	Gear <input type="checkbox"/>
Diff Oil	

NOTES

Front Shocks	
Oil	Spring
Shock Cap Sealed <input type="checkbox"/>	Vented <input type="checkbox"/> Emulsion <input type="checkbox"/>
Piston	
Drilled <input type="checkbox"/>	Hole Size mm
Shock Length mm	



Rear Shocks	
Oil	Spring
Shock Cap Sealed <input type="checkbox"/>	Vented <input type="checkbox"/> Emulsion <input type="checkbox"/>
Piston	
Drilled <input type="checkbox"/>	Hole Size mm
Shock Length mm	



Front Suspension	
Link Washers mm	Yoke 0° <input type="checkbox"/> 5° <input type="checkbox"/> Alloy <input type="checkbox"/>
Front Wishbones Kit <input type="checkbox"/> Reversed <input type="checkbox"/>	
Hub Carrier High <input type="checkbox"/> Middle <input type="checkbox"/> Low <input type="checkbox"/>	
60.0 <input type="checkbox"/> 50.5 <input type="checkbox"/> 45.5 <input type="checkbox"/> 40.5 <input type="checkbox"/>	
Front Ride Height mm	
Front Camber at Ride Height Deg	
Front Toe In Deg	

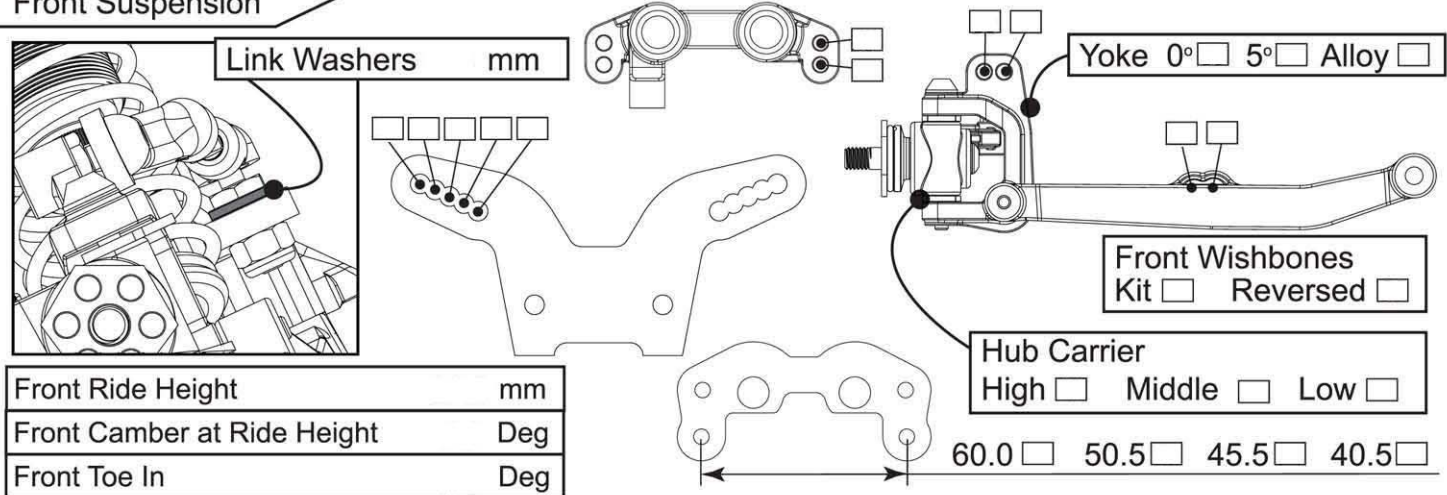

Rear Suspension	
Anti roll bar No <input type="checkbox"/> 1.00 <input type="checkbox"/> 1.20 <input type="checkbox"/> 1.40 <input type="checkbox"/> 1.60 <input type="checkbox"/>	Camber at Ride Height Deg
Wheelbase Short <input type="checkbox"/> Med <input type="checkbox"/> Long <input type="checkbox"/>	Ride Height mm
Rear Toe-in & Track Washers	
0.00 Difference = 0.00° Toe-in <input type="checkbox"/> 0.50 Difference = 0.60° Toe-in <input type="checkbox"/> 1.00 Difference = 1.30° Toe-in <input type="checkbox"/> 1.50 Difference = 1.95° Toe-in <input type="checkbox"/> 2.00 Difference = 2.60° Toe-in <input type="checkbox"/> 2.50 Difference = 3.25° Toe-in <input type="checkbox"/> 3.00 Difference = 3.90° Toe-in <input type="checkbox"/>	
Rear mm	Front mm
33.5 (1 Dink) <input type="checkbox"/> 38.0 (2 Dink) <input type="checkbox"/> 42.5 (3 Dink) <input type="checkbox"/>	
Rear Hub Carrier Alloy <input type="checkbox"/> Std <input type="checkbox"/>	
Alloy Hub Carrier +1° <input type="checkbox"/> -1° <input type="checkbox"/>	
Pin High R <input type="checkbox"/> F <input type="checkbox"/>	
Pin Low R <input type="checkbox"/> F <input type="checkbox"/>	
Link Washers mm	
Blocks Moulded <input type="checkbox"/> Alloy <input type="checkbox"/>	

