

Driver and Event	
Name	
Date	
Event	
Weather	
Result	
Track Conditions	
Grip Level	
Surface	
Track Condition	
Temperature	
Electrics	
E.S.C	
Servo	
Receiver	
Li-Po	
Motor	
Spur	
Pinion	
Internal Ratio	
Wheels - Tyres - Inserts	
Front Wheels	
Front Inserts	
Front Tyres	
Rear Wheels	
Rear Inserts	
Rear Tyres	
Transmission	
Rear Diff Height	
Front Diff Height	
Front Layshaft Pulley	
One Way <input type="checkbox"/> Fixed <input type="checkbox"/> F.A.B <input type="checkbox"/>	
Front Drive	
Front Overdrive	
Chassis	
Carbon Fibre <input type="checkbox"/> S1 <input type="checkbox"/>	

Rear Suspension

Pivot Pin Height	High <input type="checkbox"/> Low <input type="checkbox"/>
Wheelbase	Short <input type="checkbox"/> Medium <input type="checkbox"/> Long <input type="checkbox"/>
Roll Bar	No <input type="checkbox"/> 1.2 <input type="checkbox"/> 1.4 <input type="checkbox"/> 1.6 <input type="checkbox"/>

Equal Washers = 0° Toe-in
 0.50 Difference = 0.65° Toe-in
 1.00 Difference = 1.30° Toe-in
 1.50 Difference = 1.95° Toe-in
 2.00 Difference = 2.60° Toe-in
 2.50 Difference = 3.25° Toe-in
 3.00 Difference = 3.90° Toe-in

Toe-in / Rear Track Washers					
Rear	mm	Front	mm	Actual	°

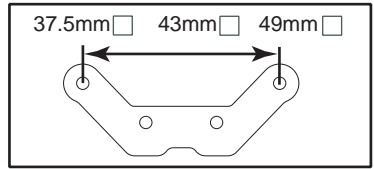
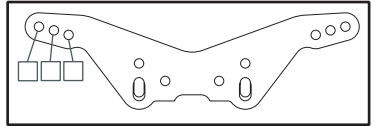
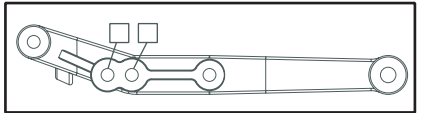
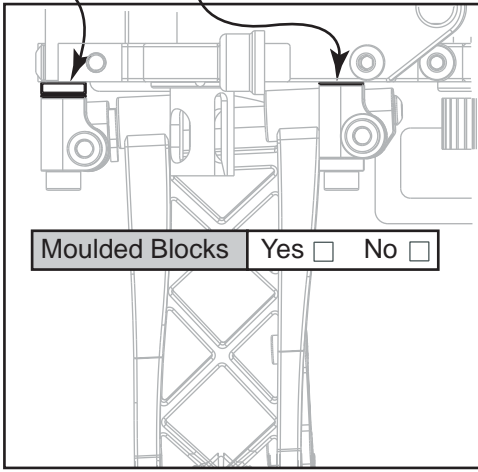

Note: The Anti-Squat Angle is worked out using the Toe-in Chart as the washers produce the same angles.

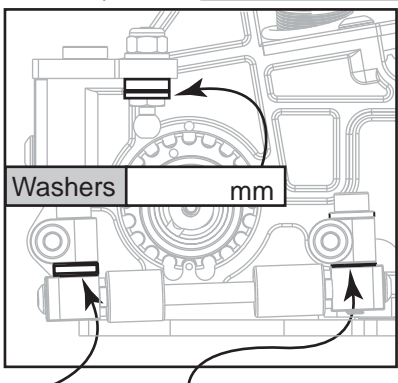

Rear	mm	Front	mm	Actual	°
Anti-Squat Washers					

Front Suspension

Front Track Washers			
Rear	mm	Front	mm

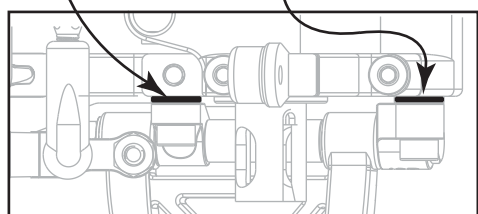

Roll Bar	No <input type="checkbox"/> 1.2 <input type="checkbox"/> 1.4 <input type="checkbox"/> 1.6 <input type="checkbox"/>
----------	--

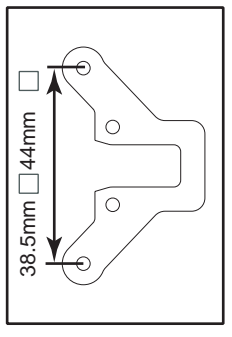
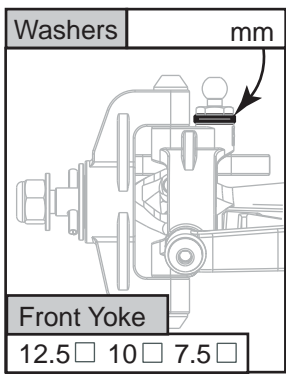
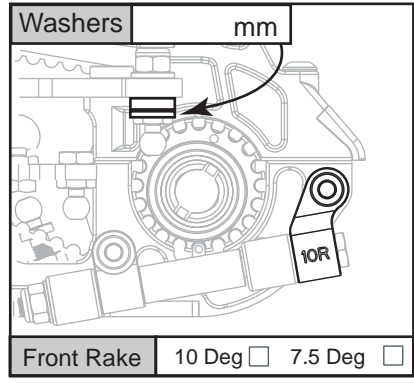
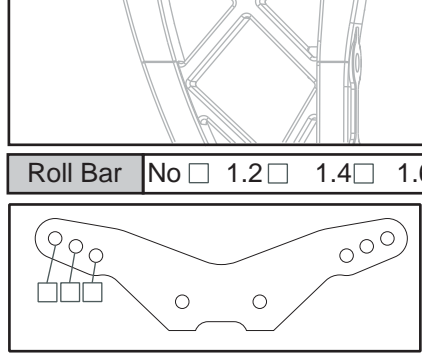

Rear Shocks

Oil		Springs	
Piston Holes	2 <input type="checkbox"/> 3 <input type="checkbox"/> 4 <input type="checkbox"/> 5 <input type="checkbox"/> 6 <input type="checkbox"/>		
Diaphragm Spec			

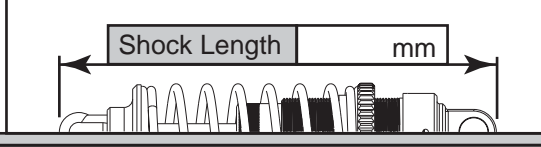

Front Shocks

Oil		Springs	
Piston Holes	2 <input type="checkbox"/> 3 <input type="checkbox"/> 4 <input type="checkbox"/> 5 <input type="checkbox"/> 6 <input type="checkbox"/>		
Diaphragm Spec			

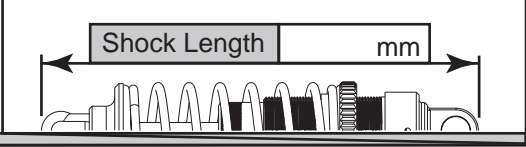

Notes	
-------	--