

Driver & Event	
Name	Larry myers
Date	
Event	
Weather	
Result	I always win

Electrics & Chassis	
E.S.C	R10 pro 1.1
Servo	Savox 1251
Receiver	Fut
Batteries	Nano Tek 6000 100c saddle
Shorty Position	Front <input type="checkbox"/> Back <input type="checkbox"/>
Transverse Shorty	Yes <input type="checkbox"/> No <input type="checkbox"/>
Chassis Stiffeners	Yes <input type="checkbox"/> No <input checked="" type="checkbox"/>
Chassis	Alloy <input checked="" type="checkbox"/> Carbon <input type="checkbox"/>

Motor & Gearing	
Motor	Leo x12
Rotor Diameter	12.5
Timing	32
Spur	83
Pinion	31

Track Conditions	
Grip Level	High <input checked="" type="checkbox"/> Med <input checked="" type="checkbox"/> Low <input type="checkbox"/>
Type	Tight <input checked="" type="checkbox"/> Open <input type="checkbox"/> Mixed <input type="checkbox"/>
Surface	Clay <input checked="" type="checkbox"/> Astro <input type="checkbox"/> Grass <input type="checkbox"/> Mixed <input type="checkbox"/> Carpet <input type="checkbox"/>
Condition	Smooth <input checked="" type="checkbox"/> Bumpy <input type="checkbox"/>

Wheels & Tyres	
Rr Tyre	Chain-link mc 2.2
Rr Wheel	Schumacher
Rr Insert	Aka red
Fr Tyre	Chain-link mc
Fr Wheel	Pro line 2.4
Fr Insert	Aka red

Notes	
Car weight	g
Wing Gurney Height	14 mm

Diff Type	
Diff Oil	
Front	Ball <input type="checkbox"/> Gear <input checked="" type="checkbox"/> 12k
Rear	Ball <input type="checkbox"/> Gear <input checked="" type="checkbox"/> 5k

Front Shocks	
Oil	Losi 25 Kit
Spring	Sealed <input type="checkbox"/>
Shock Cap	Vented <input type="checkbox"/> Emulsion <input checked="" type="checkbox"/>
Piston	Kit
Drilled	Hole Size mm
	
Shock Length24.0mm	

Rear Shocks	
Oil	Losi 30 Red
Spring	Sealed <input type="checkbox"/>
Shock Cap	Vented <input type="checkbox"/> Emulsion <input checked="" type="checkbox"/>
Piston	Kit
Drilled	Hole Size mm
	
Shock Length29.0mm	

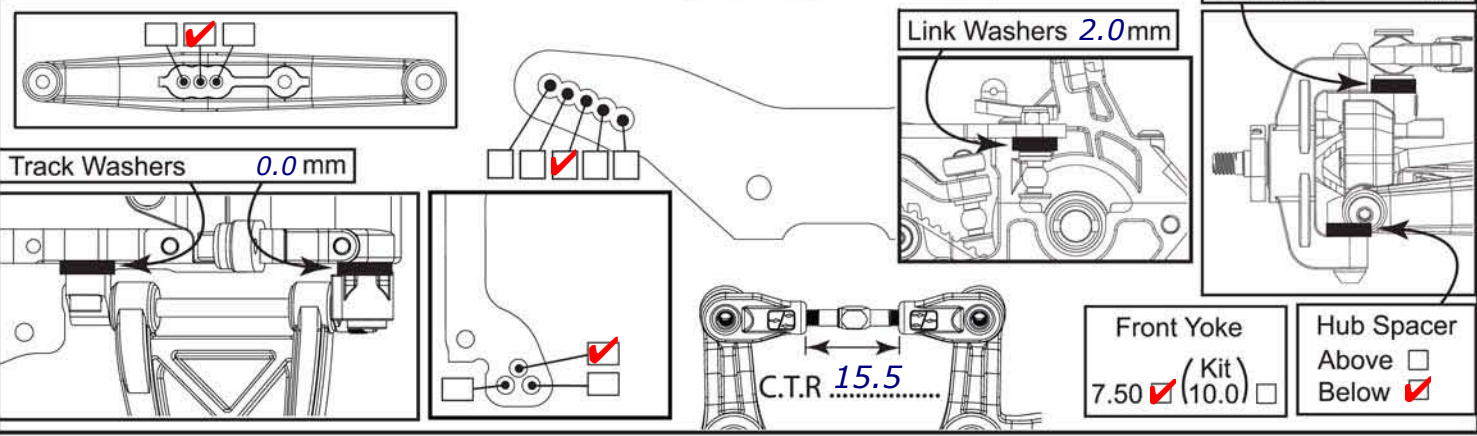
Front Suspension	
Anti roll bar	No <input type="checkbox"/> 1.4 <input checked="" type="checkbox"/> 1.6 <input type="checkbox"/> 1.8 <input type="checkbox"/> 2.0 <input type="checkbox"/>
Camber at Ride Height	3.2 Deg
Toe-In	2.0 Deg
Ride Height	18.0 mm
Washers	4.0 mm
Track Washers	0.0 mm
Link Washers	2.0 mm
Front Yoke	7.50 <input checked="" type="checkbox"/> (Kit) <input type="checkbox"/> 10.0 <input type="checkbox"/>
Hub Spacer	Above <input type="checkbox"/> Below <input checked="" type="checkbox"/>
	
C.T.R15.5	

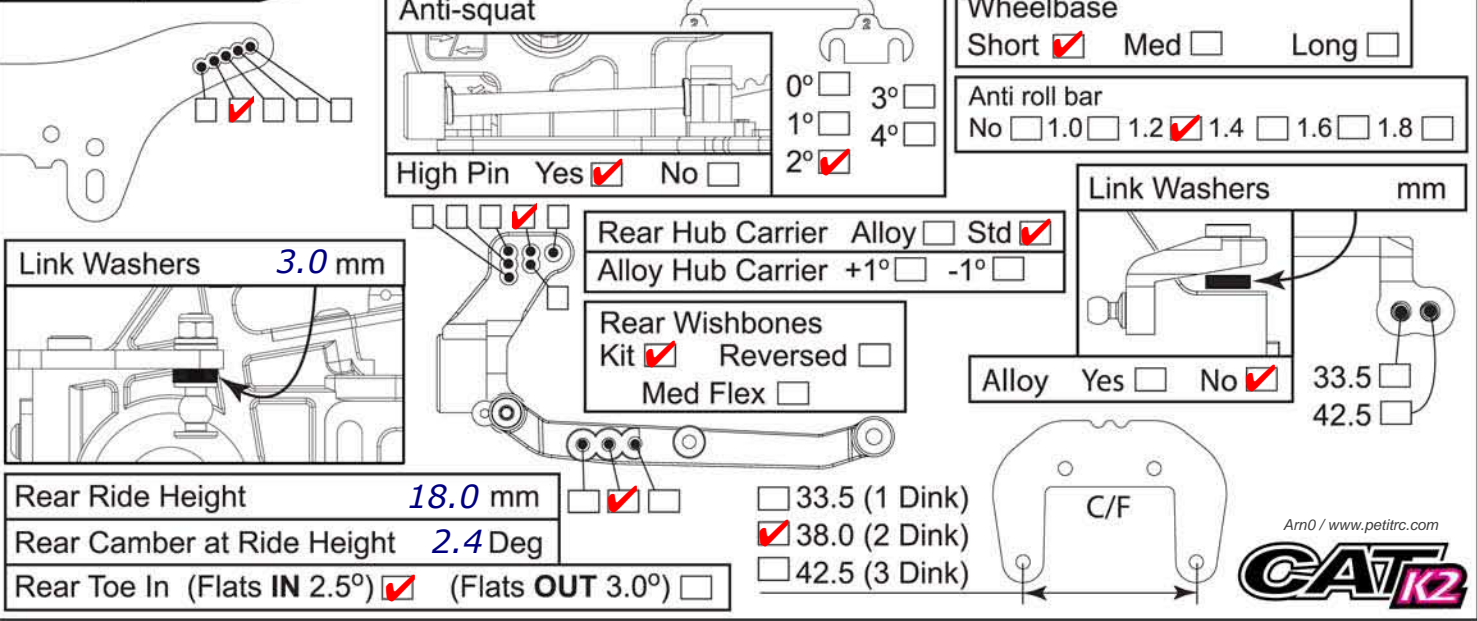
Rear Suspension	
Anti-squat	0° <input type="checkbox"/> 3° <input type="checkbox"/> 1° <input type="checkbox"/> 4° <input type="checkbox"/> 2° <input checked="" type="checkbox"/>
High Pin	Yes <input checked="" type="checkbox"/> No <input type="checkbox"/>
Wheelbase	Short <input checked="" type="checkbox"/> Med <input type="checkbox"/> Long <input type="checkbox"/>
Anti roll bar	No <input type="checkbox"/> 1.0 <input type="checkbox"/> 1.2 <input checked="" type="checkbox"/> 1.4 <input type="checkbox"/> 1.6 <input type="checkbox"/> 1.8 <input type="checkbox"/>
Link Washers	mm
Rear Hub Carrier	Alloy <input type="checkbox"/> Std <input checked="" type="checkbox"/>
Alloy Hub Carrier	+1° <input type="checkbox"/> -1° <input type="checkbox"/>
Rear Wishbones	Kit <input checked="" type="checkbox"/> Reversed <input type="checkbox"/>
Med Flex	<input type="checkbox"/>
Alloy	Yes <input type="checkbox"/> No <input checked="" type="checkbox"/>
Rear Ride Height	18.0 mm
Rear Camber at Ride Height	2.4 Deg
Rear Toe In (Flats IN 2.5°) <input checked="" type="checkbox"/>	(Flats OUT 3.0°) <input type="checkbox"/>
	
33.5 <input type="checkbox"/> 38.0 (2 Dink) <input checked="" type="checkbox"/> 42.5 (3 Dink) <input type="checkbox"/>	