

**Driver and Event**

Name **Grant Williams**

Date **Oct 2012**

Event **Astro test**

Weather **Damp**

Result **NIA**

**Track Conditions**

Surface **90% Astro**

Grip Level **Low**

Track Condition **Smooth**

**Additional Settings**

Car Weight **1672g**

Weights Added **None**

Chassis Alloy  Option

**Electrics and Gearing**

E.S.C **Nosram Comet**

Servo **Spektrum**

Receiver **Spektrum**

Batteries **Nosram 5600**

Motor **Nosram Pure 2 6.5**

Spur Gear 98T  95T

Pinion **20T**

LH Cell Position  
Forward  Backward

**Wheels and Tyres**

Rear Wheels **Sch Flexlite**

Rear Tyre **Sch Silver Minispike**

Rear Insert **Sch Med**

Front Wheels **Sch Flexlite**

Front Tyre **Sch Silver Minispike**

Front Insert **Sch Med**

NOTES

**Rear Shocks**

Shock Cap Sealed

Oil **300** Spring **2.0** Vented  Emulsion

Piston **Sch Taper Black**

Drilled  Hole Size mm

Shock Length **Kit** mm

**Front Shocks**

Shock Cap Sealed

Oil **400** Spring **4.0** Vented  Emulsion

Piston **Sch Taper White**

Drilled  Hole Size mm

Shock Length **Kit** mm

**Rear Suspension**

Anti roll bar No  1.00  1.20  1.40  1.60

Wheelbase Short  Med  Long

Camber at Ride Height **-2** mm

Ride Height **21** mm

**Anti-squat Washers**

0.00 Difference = 0.00° Toe-in

0.50 Difference = 0.60° Toe-in

1.00 Difference = 1.30° Toe-in

1.50 Difference = 1.95° Toe-in

2.00 Difference = 2.60° Toe-in

2.50 Difference = 3.25° Toe-in

3.00 Difference = 3.90° Toe-in

**Rear Toe-in & Track Washers**

0.00 Difference = 0.00° Toe-in

0.50 Difference = 0.60° Toe-in

1.00 Difference = 1.30° Toe-in

1.50 Difference = 1.95° Toe-in

2.00 Difference = 2.60° Toe-in

2.50 Difference = 3.25° Toe-in

3.00 Difference = 3.90° Toe-in

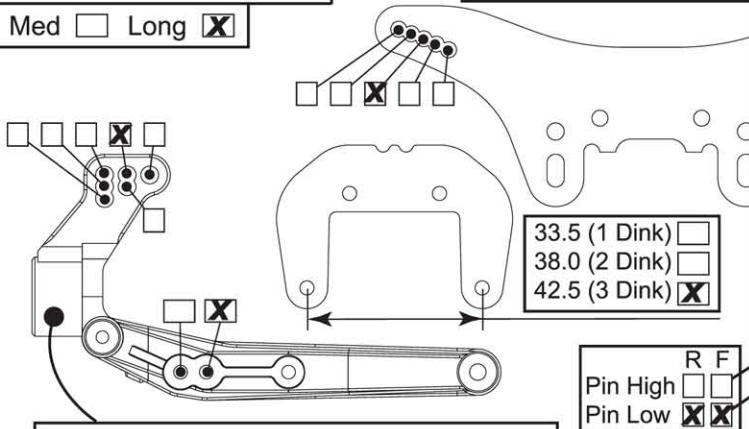

Rear **0** mm Front **0** mm

Rear Hub Carrier Alloy  Std

Alloy Hub Carrier +1°  -1°

Rear **0** mm Front **0** mm

Link Washers **1** mm

**Front Suspension**

Anti roll bar No  1.00  1.20  1.40  1.60

Camber at Ride Height **-2** mm

Toe-In **0** Deg

Ride Height **21** mm

Washers **1** mm

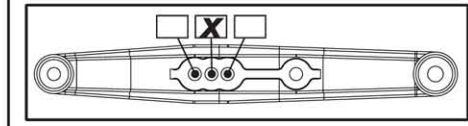

Track Washers **2** mm

Blocks Moulded  Alloy

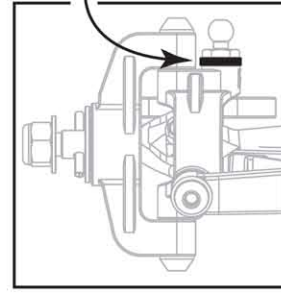
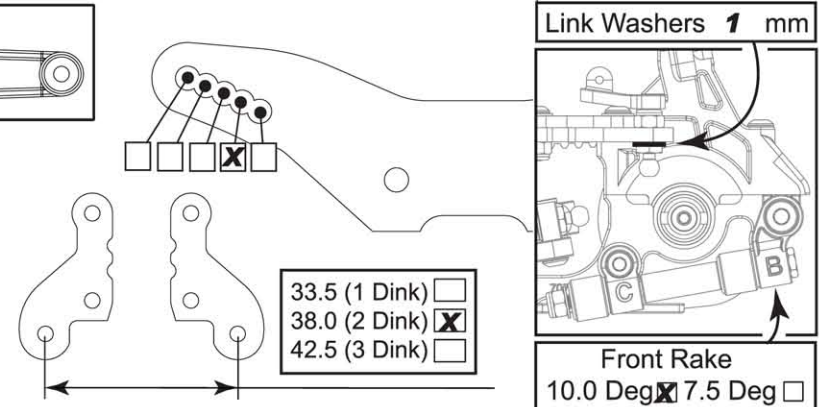

Front Yoke (Kit)

12.5  10.0  7.5

Link Washers **1** mm

Front Rake 10.0 Deg  7.5 Deg