



Driver and Event	
Name	
Date	
Event	
Weather	
Result	

Track Conditions	
Surface	
Grip Level	
Track Condition	

Additional Settings	
Car Weight	
Weights Added	
Chassis Carbon	<input type="checkbox"/>
Option	<input type="checkbox"/>
Wing Gurney Height	mm

Electrics and Gearing	
E.S.C	
Servo	
Receiver	
Batteries	
Motor	
Spur Gear	98T <input type="checkbox"/> 95T <input type="checkbox"/>
Pinion	
LH Cell Position	
Forward	<input type="checkbox"/>
Backward	<input type="checkbox"/>

Wheels and Tyres	
Rear Wheels	
Rear Tyre	
Rear Insert	
Front Wheels	
Front Tyre	
Front Insert	

Diff Type	
Diff Oil	
Front Ball	<input type="checkbox"/>
Front Gear	<input type="checkbox"/>
Rear Ball	<input type="checkbox"/>
Rear Gear	<input type="checkbox"/>

NOTES	

Rear Shocks	
Shock Cap Sealed	<input type="checkbox"/>
Oil	
Spring	
Vented	<input type="checkbox"/>
Emulsion	<input type="checkbox"/>
Piston	
Drilled	<input type="checkbox"/>
Hole Size	mm
Shock Length	mm

Front Shocks	
Shock Cap Sealed	<input type="checkbox"/>
Oil	
Spring	
Vented	<input type="checkbox"/>
Emulsion	<input type="checkbox"/>
Piston	
Drilled	<input type="checkbox"/>
Hole Size	mm
Shock Length	mm

Rear Suspension	
Anti roll bar	No <input type="checkbox"/> 1.00 <input type="checkbox"/> 1.20 <input type="checkbox"/> 1.40 <input type="checkbox"/> 1.60 <input type="checkbox"/>
Wheelbase	Short <input type="checkbox"/> Med <input type="checkbox"/> Long <input type="checkbox"/>

Camber at Ride Height	Deg
Ride Height	mm

Anti-squat Washers	
0.00 Difference = 0.00° Toe-in	<input type="checkbox"/>
0.50 Difference = 0.60° Toe-in	<input type="checkbox"/>
1.00 Difference = 1.30° Toe-in	<input type="checkbox"/>
1.50 Difference = 1.95° Toe-in	<input type="checkbox"/>
2.00 Difference = 2.60° Toe-in	<input type="checkbox"/>
2.50 Difference = 3.25° Toe-in	<input type="checkbox"/>
3.00 Difference = 3.90° Toe-in	<input type="checkbox"/>

Rear Toe-in & Track Washers	
0.00 Difference = 0.00° Toe-in	<input type="checkbox"/>
0.50 Difference = 0.60° Toe-in	<input type="checkbox"/>
1.00 Difference = 1.30° Toe-in	<input type="checkbox"/>
1.50 Difference = 1.95° Toe-in	<input type="checkbox"/>
2.00 Difference = 2.60° Toe-in	<input type="checkbox"/>
2.50 Difference = 3.25° Toe-in	<input type="checkbox"/>
3.00 Difference = 3.90° Toe-in	<input type="checkbox"/>

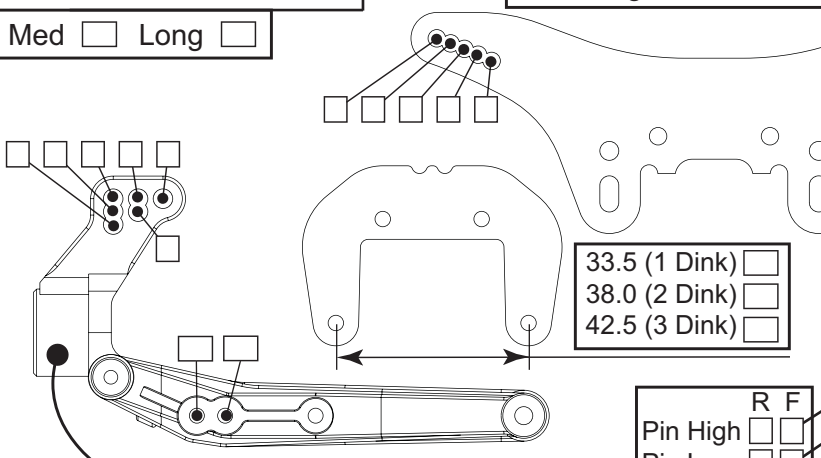

Rear	mm	Front	mm
Link Washers			
mm			

Rear	mm	Front	mm
Blocks Moulded <input type="checkbox"/> Alloy <input type="checkbox"/>			

Rear Hub Carrier	Alloy <input type="checkbox"/> Std <input type="checkbox"/>
Alloy Hub Carrier	+1° <input type="checkbox"/> -1° <input type="checkbox"/>

Front Suspension	
Anti roll bar	No <input type="checkbox"/> 1.00 <input type="checkbox"/> 1.20 <input type="checkbox"/> 1.40 <input type="checkbox"/> 1.60 <input type="checkbox"/>

Camber at Ride Height	Deg
Ride Height	mm

Toe-In	Deg
Washers	mm

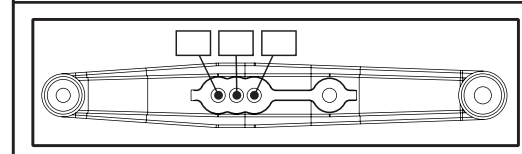

Track Washers	mm
Blocks Moulded <input type="checkbox"/> Alloy <input type="checkbox"/>	

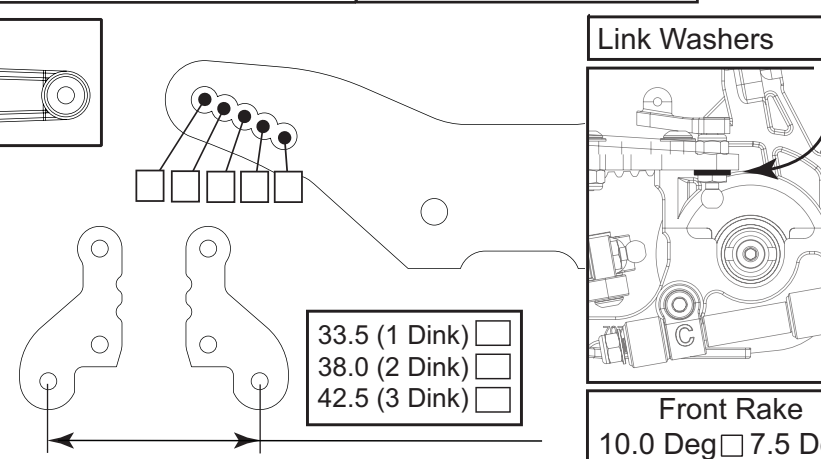

Link Washers	mm
Front Yoke (Kit)	12.5 <input type="checkbox"/> (10.0) <input type="checkbox"/> 7.5 <input type="checkbox"/>
Front Rake	10.0 Deg <input type="checkbox"/> 7.5 Deg <input type="checkbox"/>