

Driver and Event

Name _____

Date _____

Event _____

Weather _____

Result _____

Track Conditions

Surface _____

Grip Level _____

Track Condition _____



Electrics and Gearing

E.S.C _____

Servo _____

Receiver _____

Batteries _____

Motor _____

Spur Gear 98T 95T

Pinion _____

LH Cell Position
Forward Backward

Wheels and Tyres

Rear Wheels _____

Rear Tyre _____

Rear Insert _____

Front Wheels _____

Front Tyre _____

Front Insert _____

Additional Settings

Car Weight _____

Weights Added _____

Chassis C.F. Option

NOTES

Diff Type

Front	Ball <input type="checkbox"/>	Gear <input type="checkbox"/>	Diff Oil
Rear	Ball <input type="checkbox"/>	Gear <input type="checkbox"/>	

Rear Shocks

Shock Cap Sealed

Oil _____ Spring _____ Vented Emulsion

Piston _____

Drilled Hole Size _____ mm

Shock Length _____ mm

Front Shocks

Shock Cap Sealed

Oil _____ Spring _____ Vented Emulsion

Piston _____

Drilled Hole Size _____ mm

Shock Length _____ mm

Rear Suspension

Anti roll bar No 1.00 1.20 1.40 1.60

Wheelbase Short Med Long

Camber at Ride Height _____ Deg

Ride Height _____ mm

Anti-squat Washers

0.00 Difference = 0.00° Toe-in

0.50 Difference = 0.60° Toe-in

1.00 Difference = 1.30° Toe-in

1.50 Difference = 1.95° Toe-in

2.00 Difference = 2.60° Toe-in

2.50 Difference = 3.25° Toe-in

3.00 Difference = 3.90° Toe-in

Rear Toe-in & Track Washers

0.00 Difference = 0.00° Toe-in

0.50 Difference = 0.60° Toe-in

1.00 Difference = 1.30° Toe-in

1.50 Difference = 1.95° Toe-in

2.00 Difference = 2.60° Toe-in

2.50 Difference = 3.25° Toe-in

3.00 Difference = 3.90° Toe-in

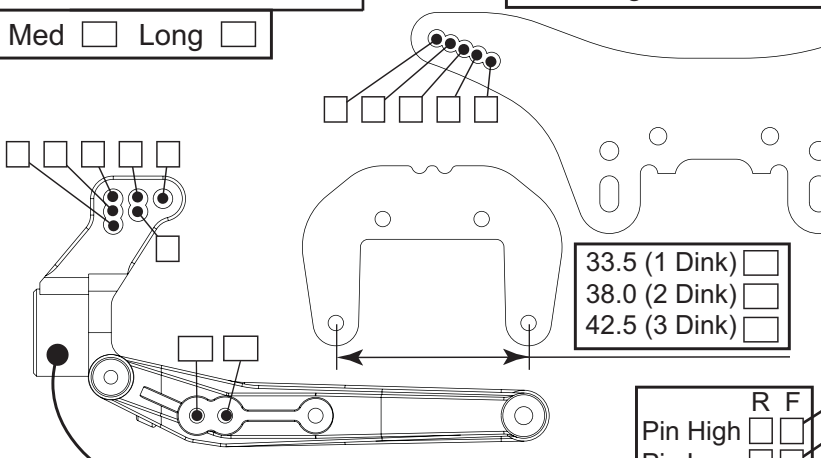

Rear mm Front mm

Link Washers mm

Rear mm Front mm

Blocks Moulded Alloy

Rear Hub Carrier Alloy Std

Alloy Hub Carrier +1° -1°

Front Suspension

Anti roll bar No 1.00 1.20 1.40 1.60

Camber at Ride Height _____ Deg

Ride Height _____ mm

Toe-In _____ Deg

Washers _____ mm

Track Washers _____ mm

Blocks Moulded Alloy

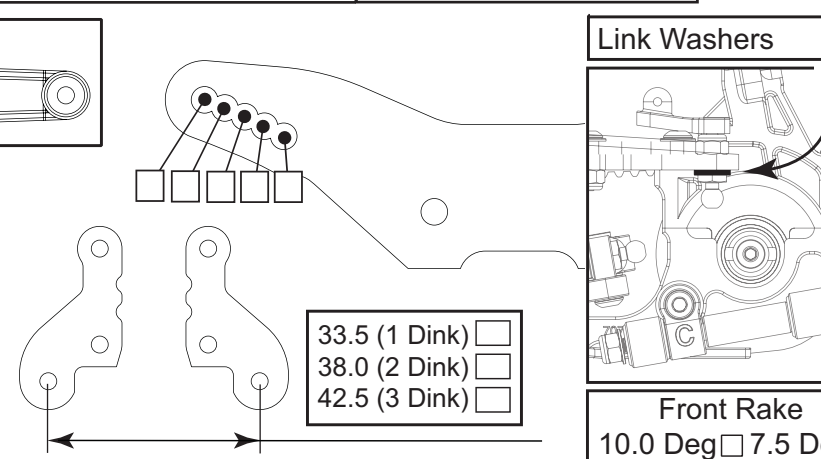

Front Yoke (Kit) 12.5 (10.0) 7.5