

# SB401

Name / 姓名 \_\_\_\_\_

Date / 日期 \_\_\_\_\_

Track/City / 跑道/城市 \_\_\_\_\_

Event / 活動 \_\_\_\_\_

## Front Suspension

Camber \_\_\_\_\_ ° Toe \_\_\_\_\_ °  
Caster \_\_\_\_\_ ° Ride Height \_\_\_\_\_

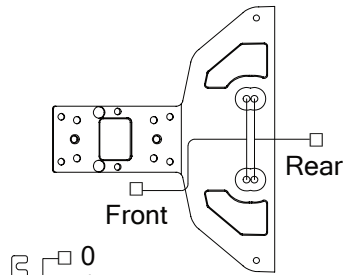

0  
1mm  
2mm  
(FF)

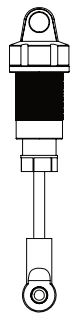
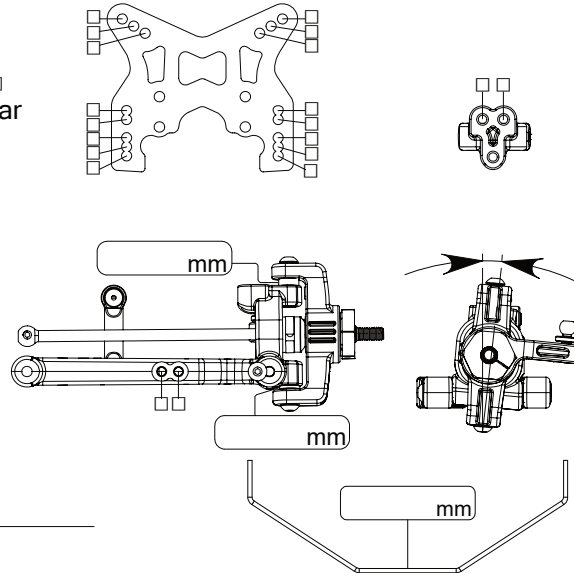

Shock Oil  
避震油 # \_\_\_\_\_  
Shock Piston  
避震活塞 \_\_\_\_\_  
Spring  
彈簧 \_\_\_\_\_  
Preload  
向下高度 \_\_\_\_\_ mm  
Limiters  
Inside \_\_\_\_\_ mm  
Outside \_\_\_\_\_ mm

## Rear Suspension

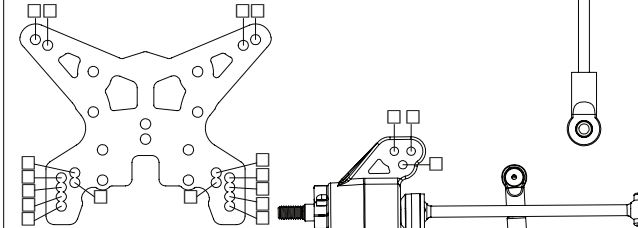
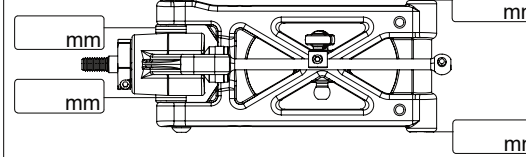

0  
1mm  
2mm  
(RF)  
2.5°  
3°

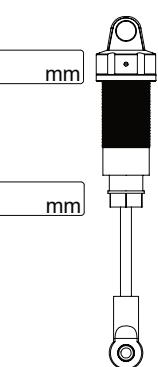

Shock Oil  
避震油 # \_\_\_\_\_  
Shock Piston  
避震活塞 \_\_\_\_\_  
Spring  
彈簧 \_\_\_\_\_  
Preload  
向下高度 \_\_\_\_\_ mm  
Limiters  
Inside \_\_\_\_\_ mm  
Outside \_\_\_\_\_ mm  
Location Front  Rear

Camber \_\_\_\_\_ °  
Ride Height \_\_\_\_\_

Straight  
 Gullwing

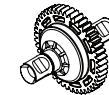

Gear Diff  
齒輪差速

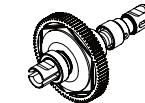

Slipper  
扭片

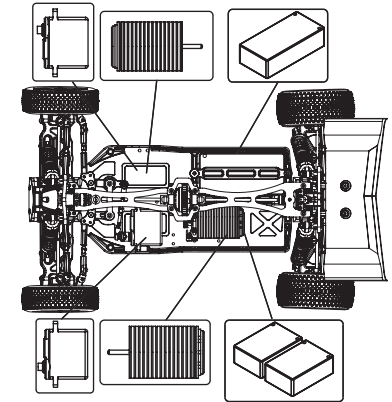

Comments \_\_\_\_\_

Diff	Front	Center	Rear
Oil			

## Tires & Wheels

### Front

Tire  
輪胎 \_\_\_\_\_  
Wheel  
輪框 \_\_\_\_\_  
Insets  
內海綿 \_\_\_\_\_  
Notes \_\_\_\_\_

### Rear

Tire  
輪胎 \_\_\_\_\_  
Wheel  
輪框 \_\_\_\_\_  
Insets  
內海綿 \_\_\_\_\_  
Notes \_\_\_\_\_

## Weather

Temperature / 溫度 \_\_\_\_\_

Humidity / 溼度 \_\_\_\_\_

## Track Conditions

Size:  Open  Med  Tight  
開放 中 小

Traction:  High  Med  Low  
高 中 低

Surface:  Smooth  Med  Bumpy  
滑 中 顛坡

Composition:  Astroturf  Carpet

Clay  Dirt  Grass  Wood

Other: \_\_\_\_\_

## Others

ESC \_\_\_\_\_

Motor  
馬達 \_\_\_\_\_

Battery  
電池 \_\_\_\_\_

Pinion/Spur  
馬達齒/齒輪 \_\_\_\_\_

Wing \_\_\_\_\_