

# S1v3 FM

MM

Name / 姓名  
Lee Romang

Date / 日期  
25/6/17

Track/City / 跑道/城市  
A1 Raceway

Event / 活動  
East Mid Regional

## Front Suspension

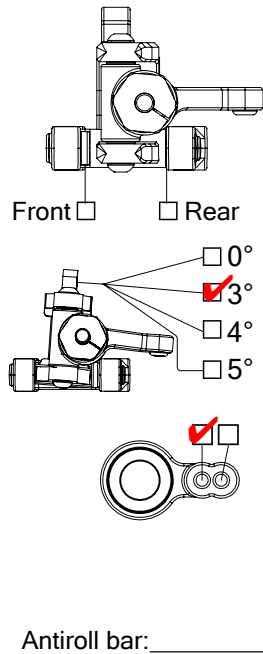
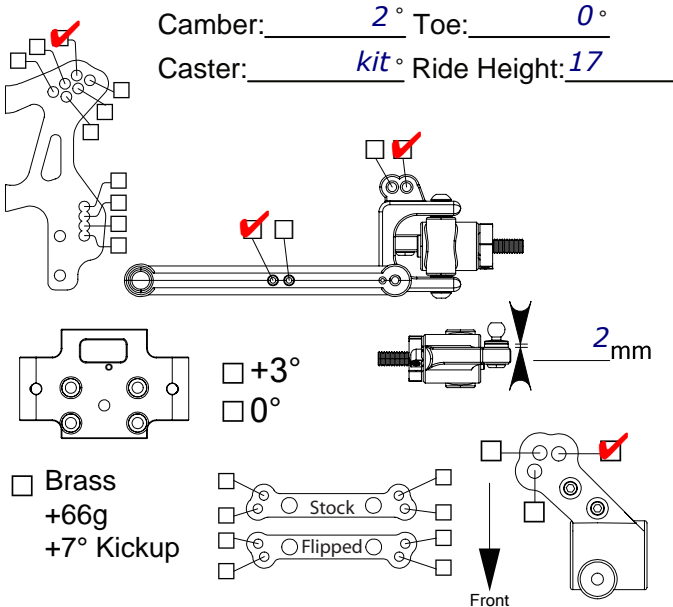

## Rear Suspension

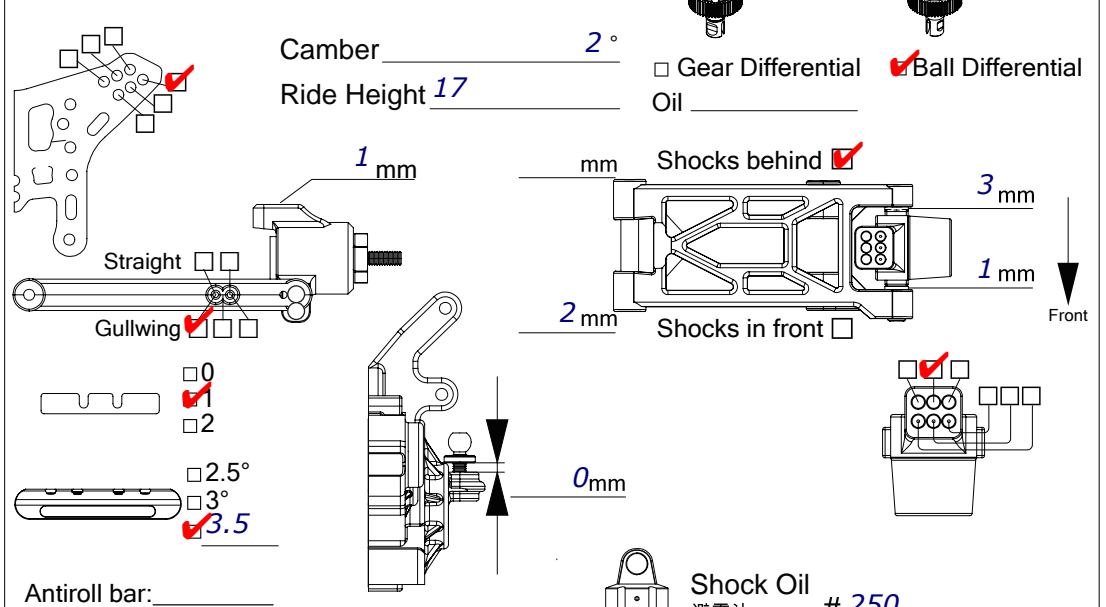

+5mm -7 degree front block  
2mm in front of caster block  
Car got better all day but did need more side bite. Went down from 300cst in the rear to 250cst. Also went to a lighter spring all round. So from orange / grey to red / white.

## Tires & Wheels

### Front

Tire Yellow Stagger  
輪胎

Wheel kit  
輪框

Insets medium  
內海綿

Notes

### Rear

Tire Yellow Mini Spike/Darts  
輪胎

Wheel kit  
輪框

Insets medium  
內海綿

Notes

Ran darts found minis better but all A final were running darts

## Weather

Temperature / 溫度

Humidity / 溼度

## Track Conditions

Size:  Open  Med  Tight  
開放 中 小

Traction:  High  Med  Low  
高 中 低

Surface:  Smooth  Med  Bumpy  
滑 中 顛坡

Composition:  Astroturf  Carpet

Clay  Dirt  Grass  Wood

Other: \_\_\_\_\_

## Others

ESC Maclan

Motor 7.5  
馬達

Battery Orion 3800  
電池

Pinion/Spur 27/kit  
馬達齒/齒輪

Wing \_\_\_\_\_