

S1v3 FM MM

Name / 姓名 _____

Date / 日期 _____

Track/City / 跑道/城市 _____

Event / 活動 _____

Front Suspension

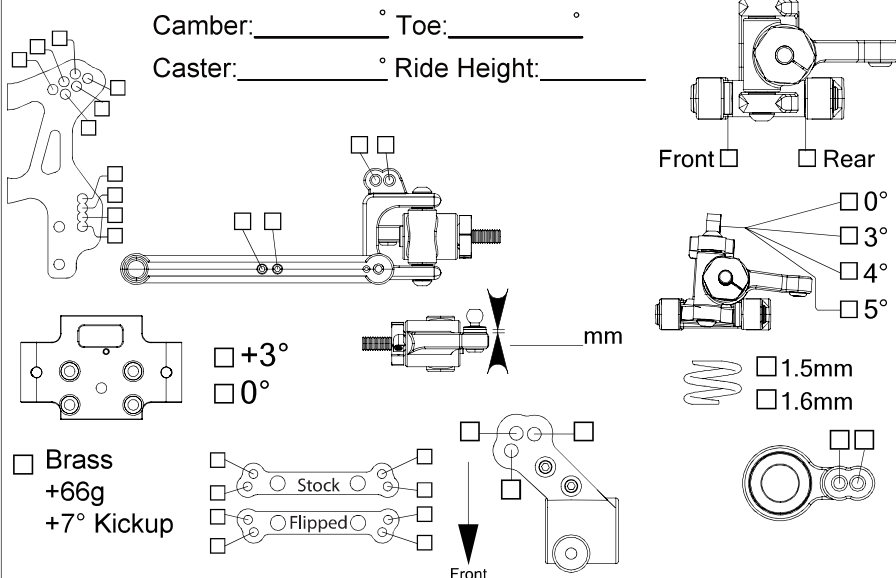

Rear Suspension

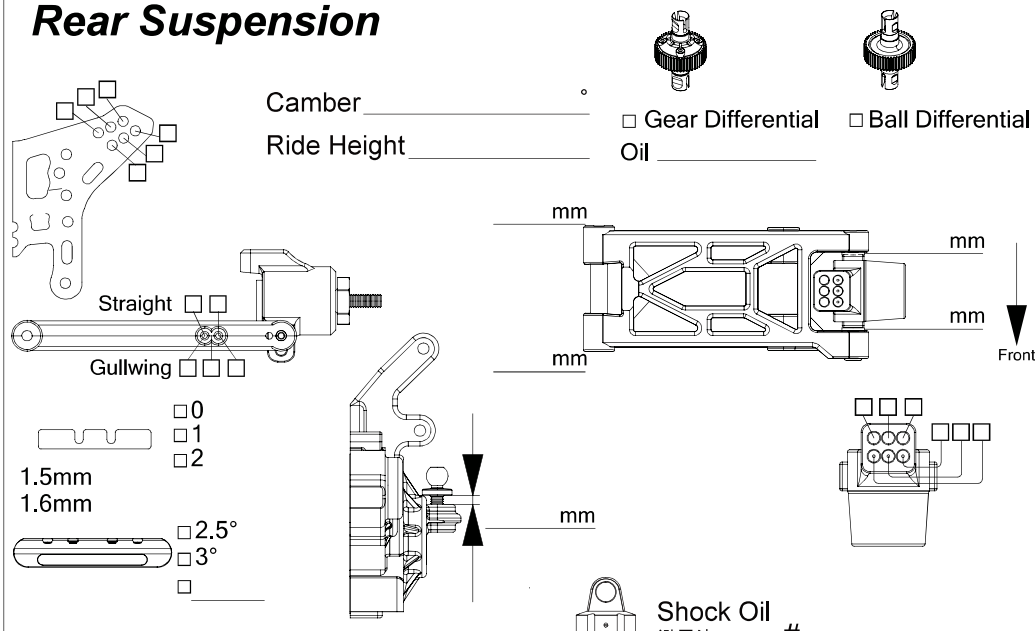

Comments: _____

Tires & Wheels

Front

Tire 輪胎 _____
 Wheel 輪框 _____
 Insets 內海綿 _____
 Notes _____

Rear

Tire 輪胎 _____
 Wheel 輪框 _____
 Insets 內海綿 _____
 Notes _____

Weather

Temperature / 溫度 _____
 Humidity / 溼度 _____

Track Conditions

Size: Open 開放 Med 中 Tight 小
 Traction: High 高 Med 中 Low 低
 Surface: Smooth 滑 Med 中 Bumpy 顛坡
 Composition: Astroturf Carpet
 Clay Dirt Grass Wood
 Other: _____

Others

ESC _____
 Motor 馬達 _____
 Battery 電池 _____
 Pinion/Spur 馬達齒/齒輪 _____
 Wing _____