

SETUP SHEET

Track Conditions

Name : *James Reilly*
 Date : *2013/11/10*
 Track : *Dirt Burner Racing, MI*

- | | | | |
|-----------|---------------------------------|--|---|
| Size: | <input type="checkbox"/> Open | <input checked="" type="checkbox"/> Med. | <input type="checkbox"/> Tight |
| Traction: | <input type="checkbox"/> High | <input checked="" type="checkbox"/> Med. | <input checked="" type="checkbox"/> Low |
| Surface: | <input type="checkbox"/> Smooth | <input checked="" type="checkbox"/> Med. | <input type="checkbox"/> Bumpy |

by ARNO at PetitRC.com

Front Suspension

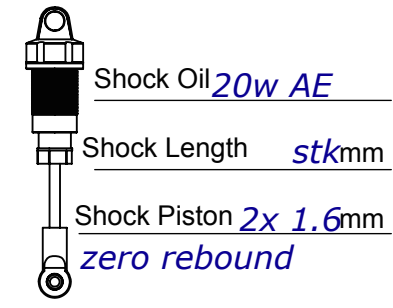
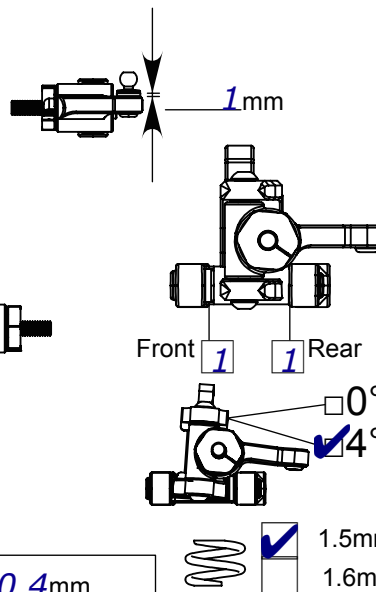
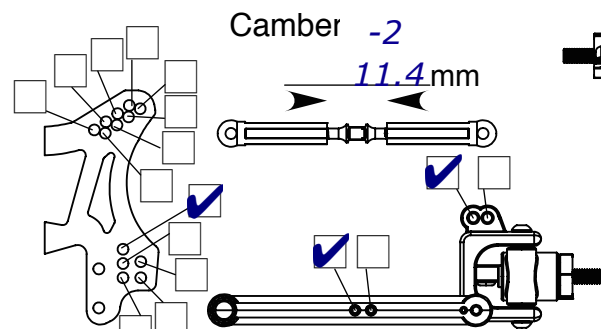

- | |
|--|
| <input type="checkbox"/> +3° |
| <input type="checkbox"/> +0° |
| <input type="checkbox"/> +3° |
| <input type="checkbox"/> +0° |
| <input checked="" type="checkbox"/> +5mm |

*66g Brass Pivot
 Plastic Tower, shocks
 middle hole*

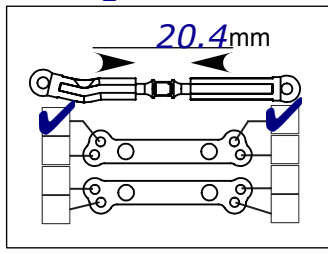

- | |
|---|
| <input type="checkbox"/> 1.1mm |
| <input type="checkbox"/> 1.0mm |
| <input checked="" type="checkbox"/> <i>BIK AE</i> |

Front

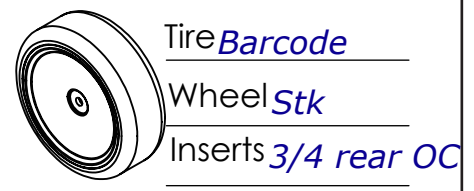

Rear Suspension

Plastic Rear Tower, shocks inside

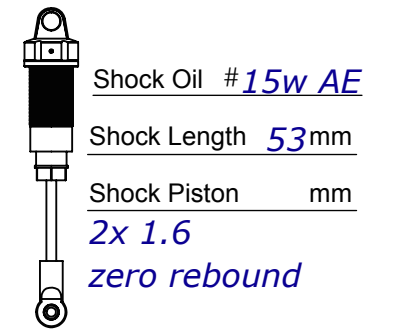
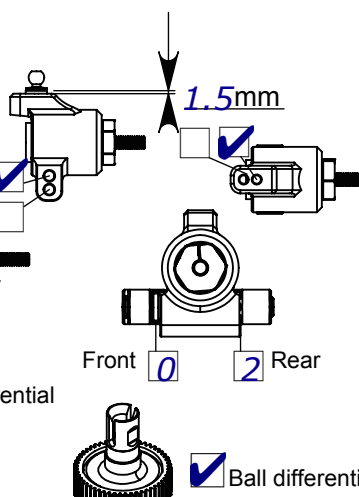
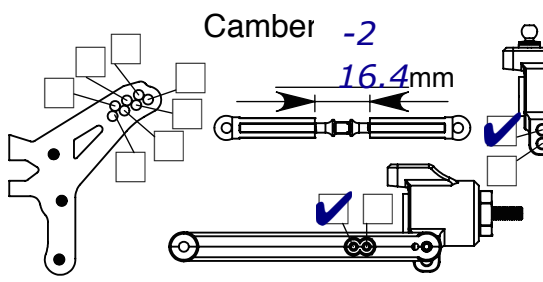

- | | |
|--|--|
| <input type="checkbox"/> 0 | <input type="checkbox"/> Bevel Gear differential |
| <input type="checkbox"/> 1 | |
| <input checked="" type="checkbox"/> 2 | |
| <input checked="" type="checkbox"/> 3° | Diff Oil # _____ |
| <input type="checkbox"/> 4° | |

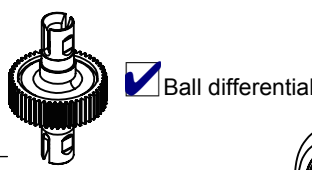

- | |
|---|
| <input type="checkbox"/> 1.1mm |
| <input type="checkbox"/> 1.0mm |
| <input checked="" type="checkbox"/> <i>White AE</i> |

Rear

