

SETUP SHEET  
for the PR S1 V2

Name \_\_\_\_\_

Date \_\_\_\_\_

Truck/City \_\_\_\_\_

Event \_\_\_\_\_

**Front Suspension**

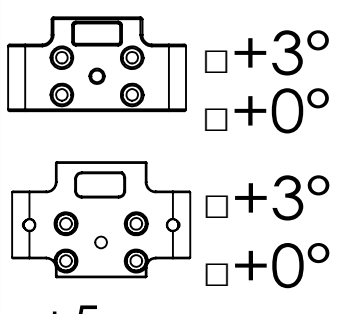
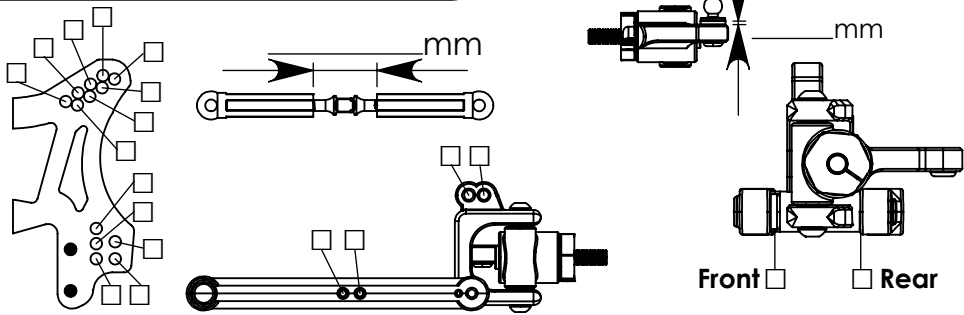

+5mm  
 Brass  
+66g  
+7 degree  
kickup

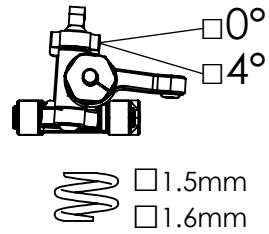
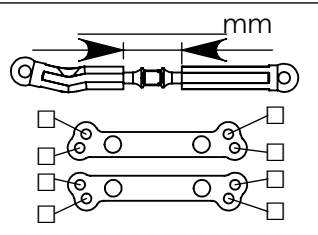
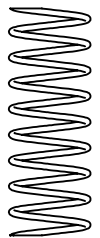

**Front**

1.1mm Shock Oil # \_\_\_\_\_

1.0mm Shock Length \_\_\_\_\_ mm

Shock Piston \_\_\_\_\_ mm

Taper Down \_\_\_\_\_ mm

**Rear Suspension**

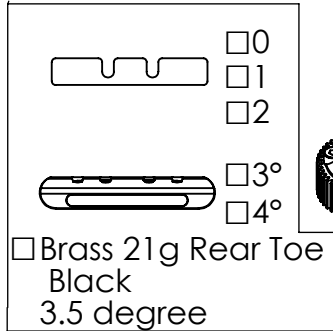
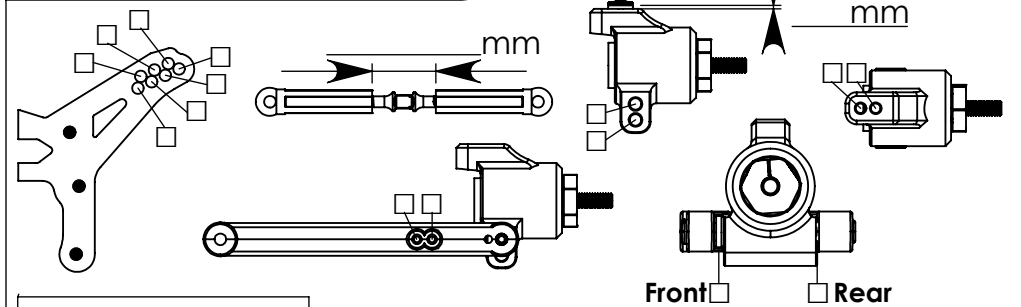

Brass 21g Rear Toe  
Black  
3.5 degree

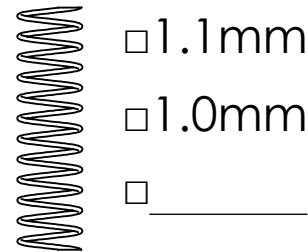

1.1mm

1.0mm

\_\_\_\_\_

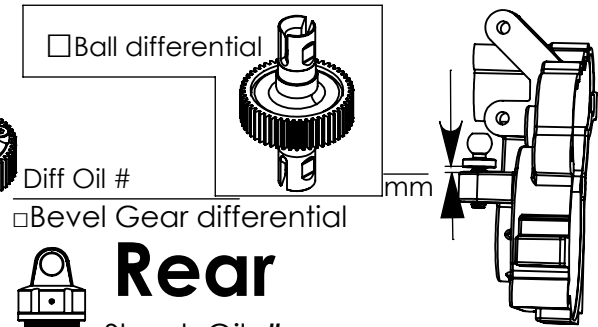

Diff Oil # \_\_\_\_\_

Bevel Gear differential

**Rear**

Shock Oil # \_\_\_\_\_

Shock Length \_\_\_\_\_ mm

Shock Piston \_\_\_\_\_ mm

Taper Down \_\_\_\_\_ mm

**Front**

**Rear**

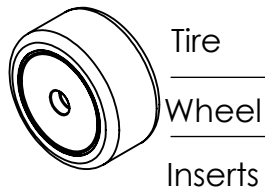
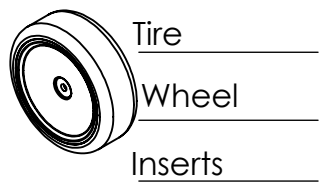

**Weather**

Temperature \_\_\_\_\_

Humidity \_\_\_\_\_

**Track Conditions**

Size:  Open  Med  Tight

Traction:  High  Med  Low

Surface:  Smooth  Med  Bumpy

**Others**

Ride Height \_\_\_\_\_ / \_\_\_\_\_

ESC/Motor \_\_\_\_\_ / \_\_\_\_\_

Battery \_\_\_\_\_

Pinion/Spur \_\_\_\_\_ / \_\_\_\_\_