

TRACK: Indoor Setup
 EVENT: _____
 DRIVER: _____ DATE: _____
 QUAL: _____ FINISH: _____

PRO-2

SETUP SHEET

FRONT SUSPENSION

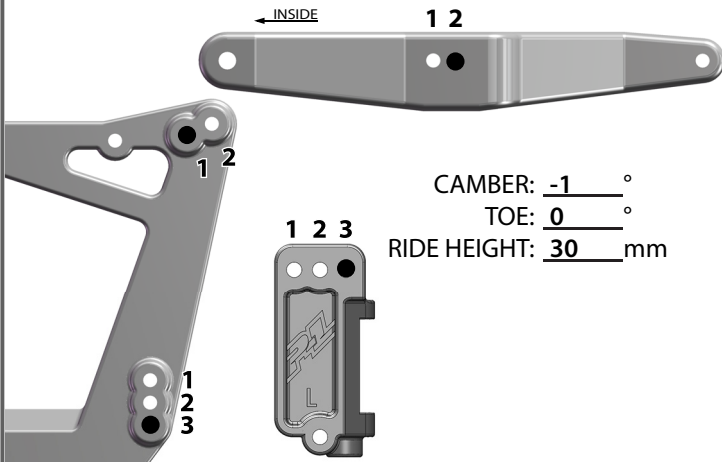

CAMBER: -1 °
 TOE: 0 °
 RIDE HEIGHT: 30 mm

POWERSTROKE FRONT SHOCKS

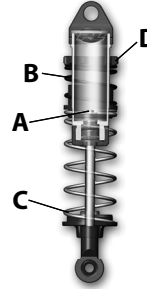

(A) PISTON: Stock
 OIL WEIGHT: 45 wt
 (B) PRIMARY SPRING: Red
 (C) SECONDARY SPRING: None
 DROOP SPACER: 4 mm
 COMPRESSION SPACER: 0 mm
 (D) SPRING ADJUSTMENT: 30 mm

REAR SUSPENSION

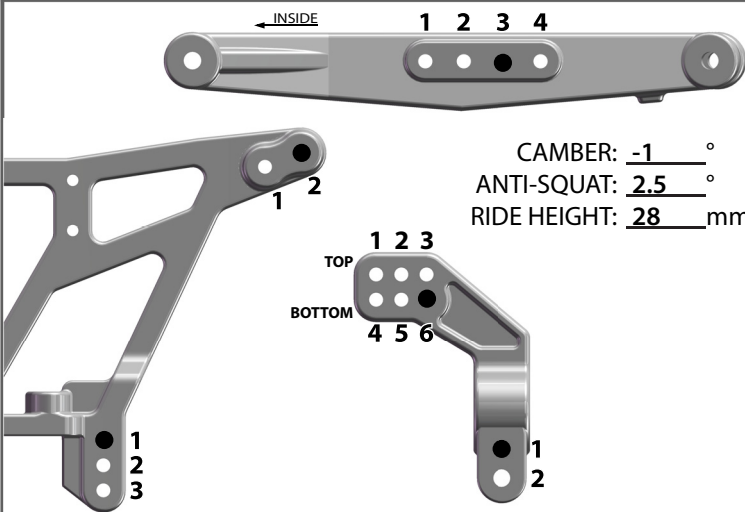

CAMBER: -1 °
 ANTI-SQUAT: 2.5 °
 RIDE HEIGHT: 28 mm

POWERSTROKE REAR SHOCKS

(A) PISTON: Stock
 OIL WEIGHT: 40 wt
 (B) PRIMARY SPRING: Yellow
 (C) SECONDARY SPRING: None
 DROOP SPACER: 7 mm
 COMPRESSION SPACER: 0 mm
 (D) SPRING ADJUSTMENT: 28 mm

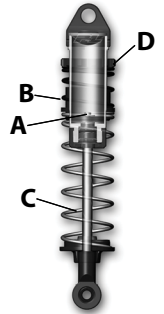

ELECTRONICS

MOTOR: NOVAK 13.5
 ESC: NOVAK
 RECEIVER: Spektrum
 SERVO: Spektrum
 RADIO: Spektrum

BATTERY PLACEMENT

BATTERY: Shorty
 PLACEMENT: Forward

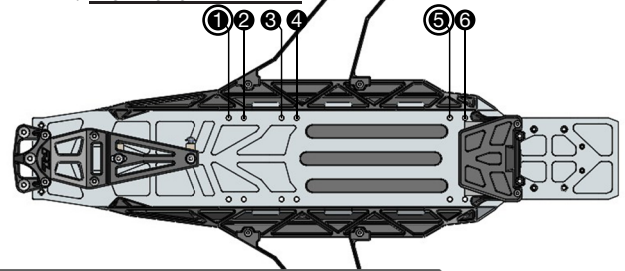

TRACK INFORMATION

TRACTION: HIGH MED LOW
 SURFACE: SMOOTH BUMPY BLUE GROOVE
 CONDITIONS: SOFT DIRT CLAY WET DUSTY
 OTHER: _____

TRANSMISSION SETTINGS

PINION: 22 tooth
 SPUR GEAR: 78 tooth
 DIFF. OIL: _____

FRONT TIRES

TIRE: ION
 COMPOUND: MC
 INSERT: Closed Cell
 WHEEL: F-11

REAR TIRES

TIRE: ION
 COMPOUND: MC
 INSERT: Closed Cell
 WHEEL: F-11

NOTES

Steering EPA: 95%
Brakes: 85%
Weights: None

RESET FORM v.1

For complete step-by-step instructions
 visit PROLINERACING.com

