

FRONT GEOMETRY

- RIDE HEIGHT _____
- DROOP _____
- TOE IN/OUT _____
- CASTER _____
- STABILIZER _____
- CAMBER _____
- NOTES _____

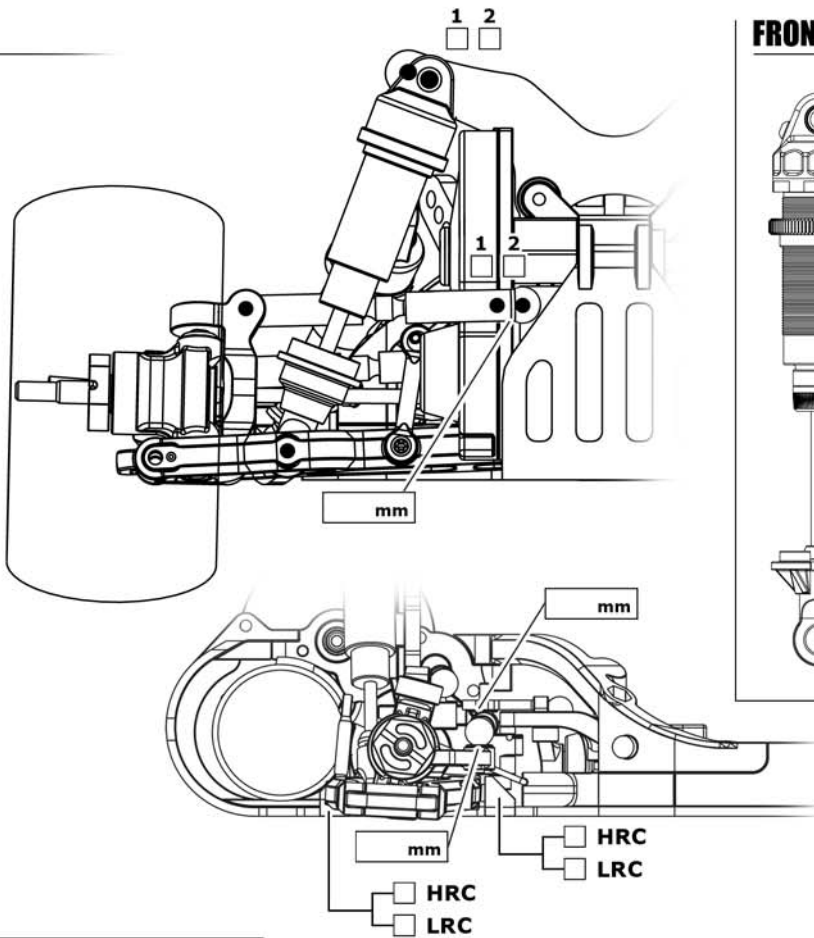

FRONT SHOCKS

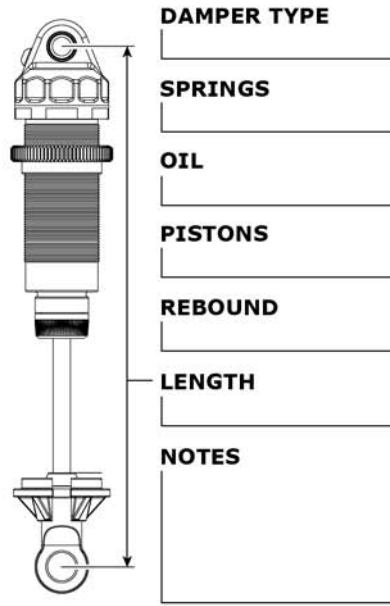

REAR GEOMETRY

- RIDE HEIGHT _____
- DROOP _____
- TOE IN/OUT _____
- STABILIZER _____
- CAMBER _____

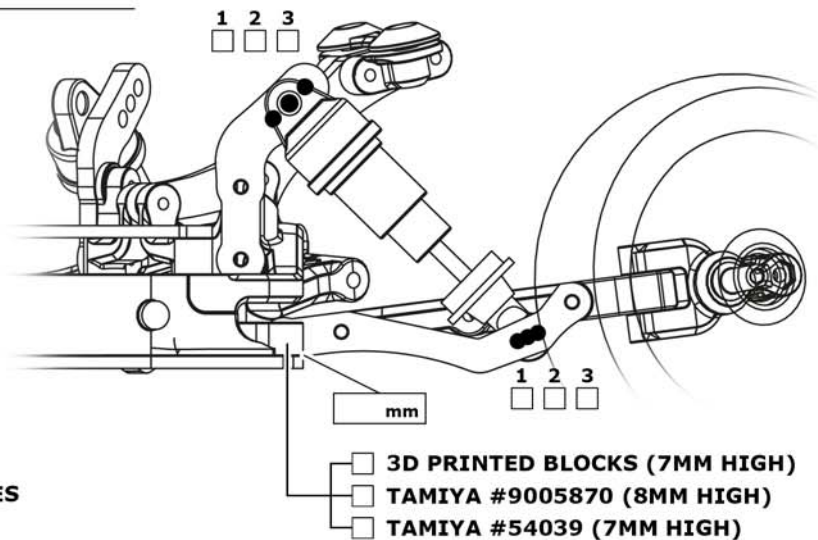

REAR SHOCKS

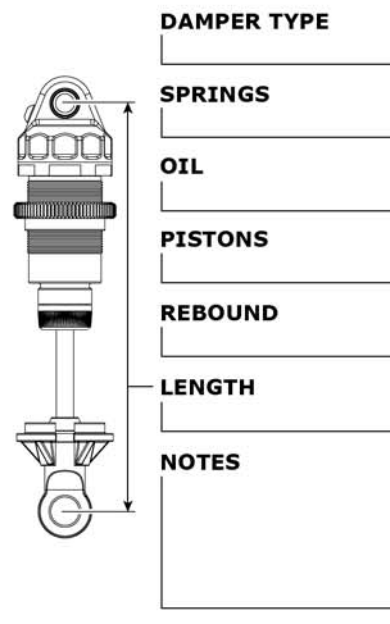

CHASSIS+ELECTRONICS

DIFFERENTIAL

SLIPPER CLUTCH

MOTOR

SPUR GEAR / PINION GEAR

ESC TYPE

PUNCH & BOOST SETTINGS

BRAKE & DRAG BRAKE SETTINGS

SERVO

BATTERY & LOCATION

WING

WEIGHT

WEIGHT BALANCE FRONT/REAR

WIDTH FRONT & REAR

NOTES

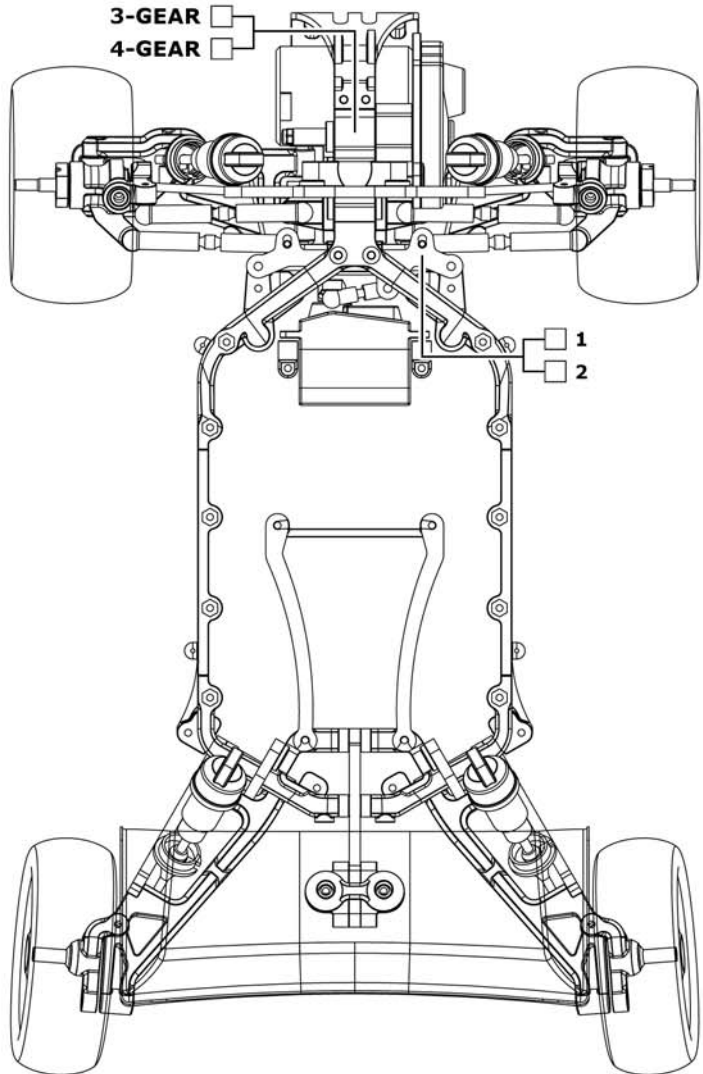

FRONT TIRES

BRAND

TREAD+COMPOUND

INSERT

RIMS

NOTES

REAR TIRES

BRAND

TREAD+COMPOUND

INSERT

RIMS

NOTES

SETUP COMMENTS

