

# Motogo Seiki DMX410

Driver:  
Event:

Date:  
City:

Composition - Astroturf Blue Groove Clay Dirt Carpet Wood  
Traction - Low Medium High  
Surface - Bumpy Smooth Dry Wet

## Front

Camber:  
Caster:  
Toe:  
Ride Height:  
Diff Oil:  
Sway Bar:  
Notes:

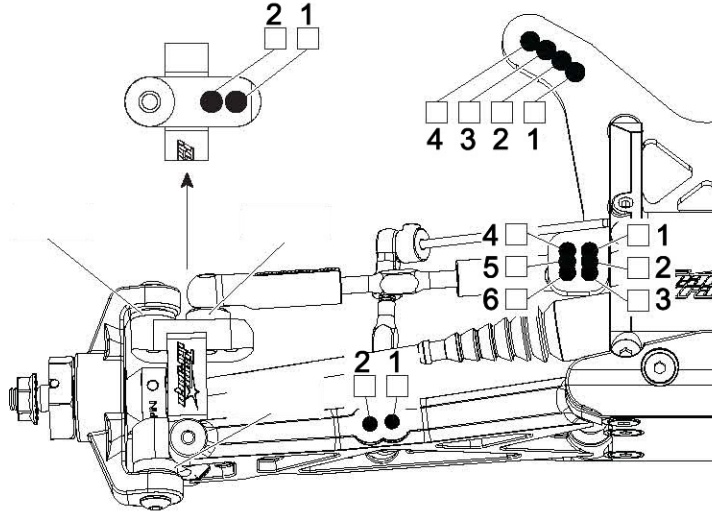

## Front shock



Brand:  
Piston:  
Spring:  
Oil:  
Rebound:  
Preload:  
Length:  
Notes:

## Rear

Camber:  
Ride Height:  
Diff Oil:  
Sway Bar:  
ARB Link:  
Notes:

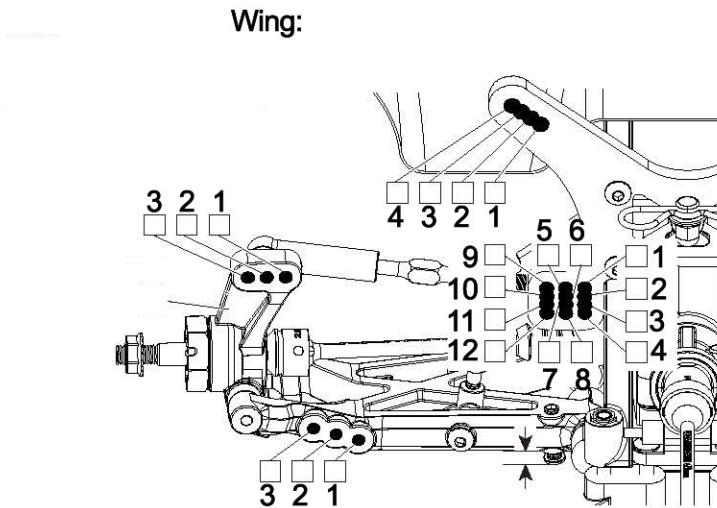

## Rear shock



Brand:  
Piston:  
Spring:  
Oil:  
Rebound:  
Preload:  
Length:  
Notes:

## Electronics

Motor:  
Pinion:  
Spur:  
ESC:  
Setting:

Battery:  
Servo:  
Receiver:  
Body:

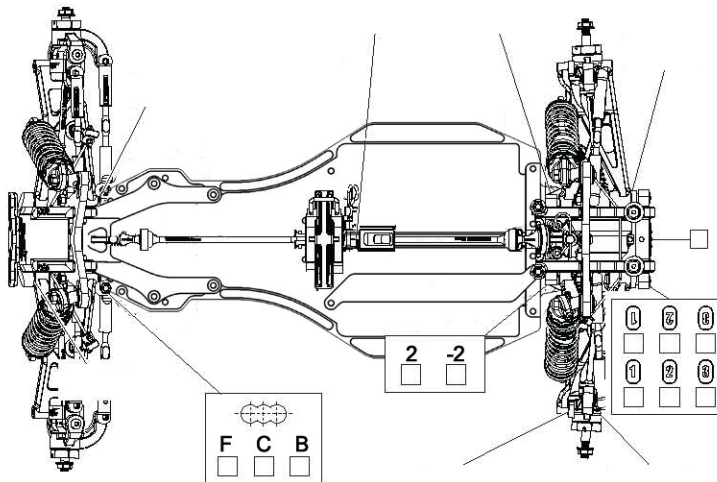

## Front tires

Tire:  
Insert:  
Wheel:

## Rear tires

Tire:  
Insert:  
Wheel:

## Result

Qualif:

Final:

Notes: