



Name: <u>22T RTR Base Setup</u>		Date: _____	Event: _____
City: _____		State: _____	
Track: _____			
Track Conditions	<input type="checkbox"/> Indoor <input type="checkbox"/> Tight <input type="checkbox"/> Smooth <input type="checkbox"/> Hard Packed <input type="checkbox"/> Blue Groove	<input type="checkbox"/> Wet <input type="checkbox"/> Grass <input type="checkbox"/> Low Bite <input type="checkbox"/> High Bite	
	<input type="checkbox"/> Outdoor <input type="checkbox"/> Open <input type="checkbox"/> Rough <input type="checkbox"/> Loose/Loamy <input type="checkbox"/> Dry	<input type="checkbox"/> Dusty <input type="checkbox"/> AstroTurf <input type="checkbox"/> Med Bite <input type="checkbox"/> Other _____	

Front Suspension

Toe: 0 degree

Ride Height: 31mm

Camber: -1 degree

Caster: 0° 3° 5° 10°

Kick Angle: 20° 25° 30°

Sway Bar: No

Shock Type: Bladder Emulsion Oil: 27.5wt

Piston: 56

Spring: Green (Truck Front Spring-TLR5182)

Shock Limiters: 4mm

Shock Location: #1 on tower/inside on arm

Bump Steer: 0mm

Camber Link: #1

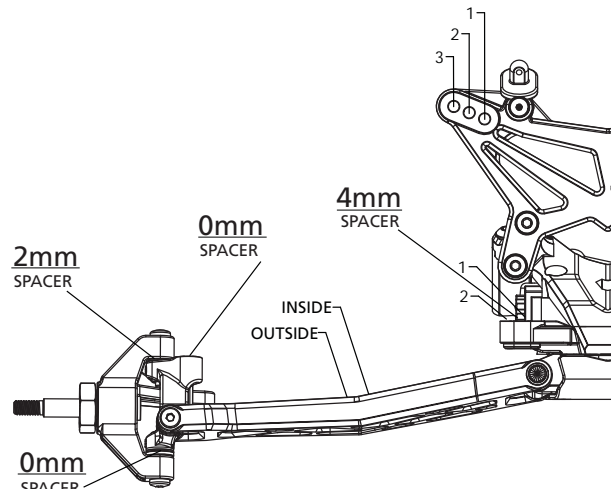

Notes: _____

Rear Suspension

Chassis Configuration: Rear Motor Mid Motor

Differential: Ball Diff Gear Diff Gear Diff Fluid: 1000wt

Toe: 4 degrees

Anti-Squat: 2.5 degrees

Roll Center: Low Roll Center (LRC) High Roll Center (HRC)

Ride Height: 29mm

Camber: -1 degrees

Rear Hub Spacing: Middle

Hex Width: Stock

Sway Bar: No

Shock Type: Bladder Emulsion Oil: 27.5wt

Piston: 55

Spring: Pink (Buggy Rear Spring- TLR5168)

Shock Limiters: 2mm

Camber Link: 2/B

Shock Locations: #2 on tower/inside on arm

Spoiler: Stock

Battery Position: Forward

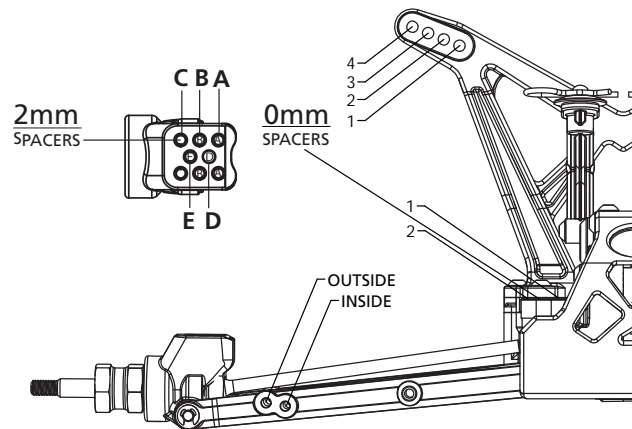

Electronics

Radio: _____	Timing Advance: _____
Servo: _____	Throttle/Brake Expo: _____
ESC: _____	Servo Expo: _____
Initial Brake: _____	Throttle/Brake EPA: _____
Drag Brake: _____	Motor: <u>Losi 13.5</u>
Throttle Profile: _____	Pinion: <u>23</u> Spur: <u>82</u>
	Battery: _____

<p>Weight Placement (Mark with "X")</p> <p>Weight of each piece _____ oz./g</p>	Tires	Compound	Insert	Additive
	Front: <u>BK Bar</u>	<u>Blue</u>	_____	_____
	Rear: <u>BK Bar</u>	<u>White</u>	_____	_____
Notes: _____				