

Name: _____		Date: _____	Event: _____
City: _____ State: _____		Track: _____	
Track Conditions	<input type="checkbox"/> Indoor <input type="checkbox"/> Tight <input type="checkbox"/> Smooth <input type="checkbox"/> Hard Packed <input type="checkbox"/> Blue Groove	<input type="checkbox"/> Wet <input type="checkbox"/> Grass <input type="checkbox"/> Low Bite <input type="checkbox"/> High Bite	<input type="checkbox"/> Med Bite <input type="checkbox"/> Other _____
	<input type="checkbox"/> Outdoor <input type="checkbox"/> Open <input type="checkbox"/> Rough <input type="checkbox"/> Loose/Loamy <input type="checkbox"/> Dry	<input type="checkbox"/> Dusty <input type="checkbox"/> Astroturf	

**FRONT SUSPENSION**

Toe: \_\_\_\_\_

Ride Height: \_\_\_\_\_

Camber: \_\_\_\_\_

Caster:  0°  5° Trail:  2mm  4mm

Kick Angle:  20°  25°  30°

Oil: \_\_\_\_\_

Piston: \_\_\_\_\_

Spring:  Standard  Low Freq. Color: \_\_\_\_\_

Front Pivot:  Aluminum  Plastic  HRC

Kick Shim:  Brass  Plastic

Shock Limiters: \_\_\_\_\_ Stroke: \_\_\_\_\_

Shock Location: \_\_\_\_\_

Steering Type:  Slide Rack  Bell Cranks

Spindle Ball Stud:  Standard  Low Mount

Bumper Steer Spacers: \_\_\_\_\_

Ackermann Ball Stud:  Standard  Low Mount

Ackermann Spacers: \_\_\_\_\_

Camber Link: \_\_\_\_\_

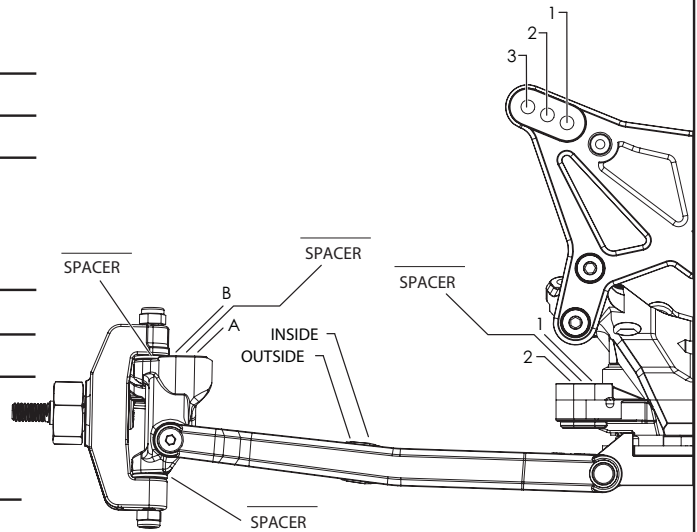

Notes: \_\_\_\_\_

**REAR SUSPENSION**

Chassis Configuration:  Rear Motor  Mid Motor

Toe: \_\_\_\_\_

Anti-Squat: \_\_\_\_\_

Roll Center:  Low Roll Center (LRC)  High Roll Center (HRC)

Ride Height: \_\_\_\_\_

Camber: \_\_\_\_\_

Rear Hub Spacing: \_\_\_\_\_

Hex Width: \_\_\_\_\_

Oil: \_\_\_\_\_

Piston: \_\_\_\_\_

Spring:  Standard  Low Freq. Color: \_\_\_\_\_

Shock Limiters: \_\_\_\_\_ Stroke: \_\_\_\_\_

Camber Link: \_\_\_\_\_

Shock Locations: \_\_\_\_\_

Body/Cut Outs: \_\_\_\_\_

Battery Position: \_\_\_\_\_

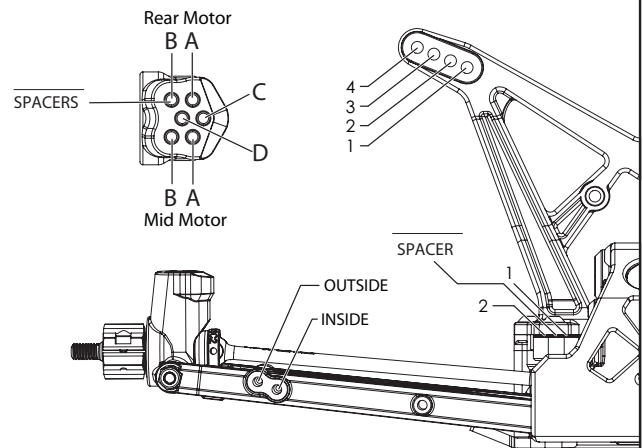

**ELECTRONICS**

Radio: \_\_\_\_\_ Timing Advance: \_\_\_\_\_

Servo: \_\_\_\_\_ Throttle/Brake Expo: \_\_\_\_\_

ESC: \_\_\_\_\_ Servo Expo: \_\_\_\_\_

Initial Brake: \_\_\_\_\_ Throttle/Brake E PA: \_\_\_\_\_

Drag Brake: \_\_\_\_\_ Motor: \_\_\_\_\_

Throttle Profile: \_\_\_\_\_ Pinion: \_\_\_\_\_ Spur: \_\_\_\_\_

Battery: \_\_\_\_\_

**WEIGHT PLACEMENT**

**TIRES**

Tread \_\_\_\_\_ Compound \_\_\_\_\_ Insert \_\_\_\_\_ Additive \_\_\_\_\_

Front: \_\_\_\_\_

Rear: \_\_\_\_\_

Notes: \_\_\_\_\_

