

NAME: \_\_\_\_\_ DATE: \_\_\_\_\_

EVENT: \_\_\_\_\_ TRACK: \_\_\_\_\_



TRACK CONDITIONS:  Indoor  Tight  Smooth  Hard Packed  Blue Groove  Wet  Grass  Low Bite  Med Bite  High Bite  
 Outdoor  Open  Rough  Loose/Loamy  Dry  Dusty  AstroTurf  Other \_\_\_\_\_

**FRONT SUSPENSION**

Toe: \_\_\_\_\_  
 Ride Height: \_\_\_\_\_ Camber: \_\_\_\_\_  
 Caster:  0°  5°  
 Kick Angle:  20°  25°  30°  
 VLA Setting:  Short Arm  Long Arm  
 Oil: \_\_\_\_\_  
 Piston: \_\_\_\_\_  
 Spring:  Standard  Low Freq. Color: \_\_\_\_\_  
 Front Pivot:  Aluminum  Plastic  HRC  
 Kick Shim:  Brass  Plastic  
 Shock Limiters: \_\_\_\_\_ Stroke: \_\_\_\_\_  
 Shock Location: \_\_\_\_\_  
 Steering Type:  Slide Rack  Bell Cranks  
 Spindle Ball Stud:  Standard  Low Mount  
 Bumper Steer Spacers: \_\_\_\_\_  
 Ackermann Ball Stud:  Standard  Low Mount  
 Ackermann Spacers: \_\_\_\_\_  
 Ackerman Arm:  #1  #2  #3  \_\_\_\_\_  
 Trail:  2mm  3mm  4mm  
 Camber Link: \_\_\_\_\_

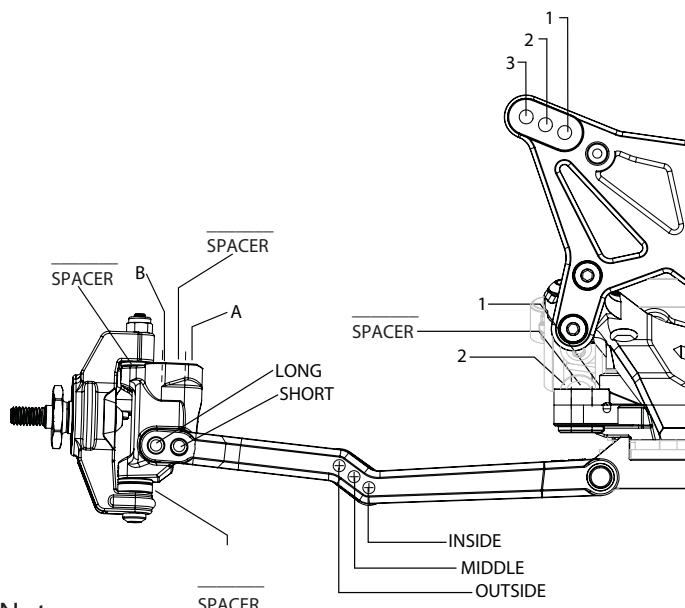

Notes:

**REAR SUSPENSION**

Transmission Type:  3-Gear  4-Gear  Laydown  
 Toe Inserts:  0.5°  1°  1.5°  2°  2.5°  3°  3.5°  4°  
 Anti-Squat Inserts:  0°  .5°  1°  1.5°  2°  2.5°  3°  
 Roll Center:  Low Roll Center (LRC)  High Roll Center (HRC)  
 Ride Height: \_\_\_\_\_ Camber: \_\_\_\_\_  
 Rear Hub Spacing: \_\_\_\_\_  
 Hex Width: \_\_\_\_\_  
 Sway Bar: \_\_\_\_\_  
 Oil: \_\_\_\_\_  
 Piston: \_\_\_\_\_  
 Spring:  Standard  Low Freq. Color: \_\_\_\_\_  
 Shock Limiters: \_\_\_\_\_ Stroke: \_\_\_\_\_  
 Shock Location: \_\_\_\_\_  
 Inner Link Spacer:  -1mm  0mm  +1mm  
 Camber Link: \_\_\_\_\_  
 Body: \_\_\_\_\_  
 Battery Position: \_\_\_\_\_  
 Diff Type:  Ball  Gear Setting: \_\_\_\_\_

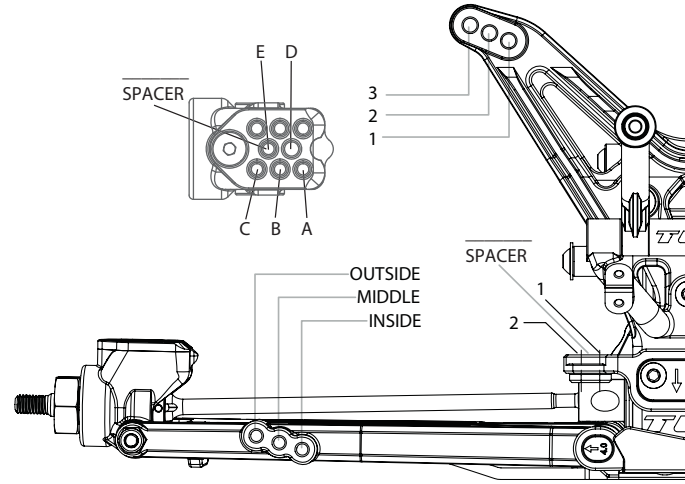

**ELECTRONICS**

Timing Advance: \_\_\_\_\_  
 Radio: \_\_\_\_\_ Throttle/Brake Expo: \_\_\_\_\_  
 Servo: \_\_\_\_\_ Servo Expo: \_\_\_\_\_  
 ESC: \_\_\_\_\_ Throttle/Brake EPA: \_\_\_\_\_  
 Initial Brake: \_\_\_\_\_ Motor: \_\_\_\_\_  
 Drag Brake: \_\_\_\_\_ Pinion: \_\_\_\_\_ Spur: \_\_\_\_\_  
 Throttle Profile: \_\_\_\_\_ Battery: \_\_\_\_\_

Weight Placement (Mark with "X")	TIRES Brand & Type	Compound	Insert	Additive
Front: _____	Front: _____	_____	_____	_____
Rear: _____	Rear: _____	_____	_____	_____
Notes: _____	Notes: _____	_____	_____	_____

