

|                          |                          |
|--------------------------|--------------------------|
| Name: _____              | Date: _____ Event: _____ |
| City: _____ State: _____ | Track: _____             |

Track Conditions:  Indoor  Outdoor  Tight  Open  Smooth  Rough  Hard Packed  Loose/Loamy  Blue Groove  Dry  Wet  Dusty  Grass  Astro Turf  Low Bite  Med Bite  High Bite  Other \_\_\_\_\_

**Front Suspension**

Toe: \_\_\_\_\_  
 Ride Height: \_\_\_\_\_  
 Camber: \_\_\_\_\_  
 Caster:  10°  15°  20°  
 Sway Bar: \_\_\_\_\_  
 Oil: \_\_\_\_\_  
 Piston: \_\_\_\_\_  
 Spring:  Standard  Low Freq. Color: \_\_\_\_\_  
 Shock Limiters: \_\_\_\_\_  
 Shock Location: \_\_\_\_\_  
 Bump Steer Ball Stud:  Standard  Low Mount  
 Bumper Steer Spacers: \_\_\_\_\_  
 Camber Link: \_\_\_\_\_  
 Ackermann: \_\_\_\_\_  
 Notes: \_\_\_\_\_

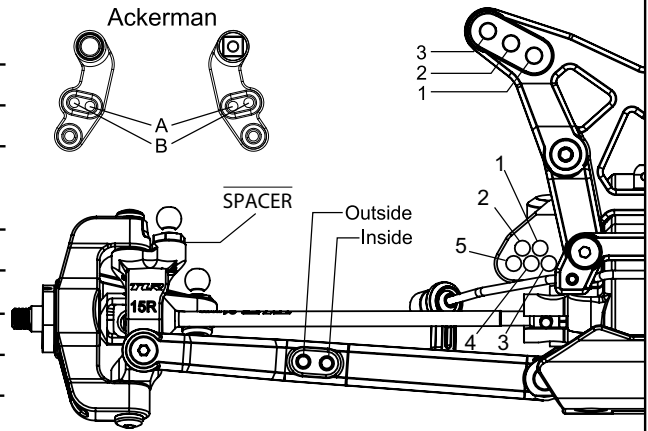

- TLR331012 Aluminum Servo Mount
- TLR334007 Aluminum Front Spindle
- TLR334009 Aluminum Steering Bellcrank

**Rear Suspension**

Toe: \_\_\_\_\_  
 Anti-Squat: \_\_\_\_\_  
 Roll Center:  Low Roll Center (LRC)  High Roll Center (HRC)  
 Ride Height: \_\_\_\_\_  
 Camber: \_\_\_\_\_  
 Rear Hub Spacing: \_\_\_\_\_  
 Hex Width: \_\_\_\_\_  
 Sway Bar: \_\_\_\_\_  
 Oil: \_\_\_\_\_  
 Piston: \_\_\_\_\_  
 Spring:  Standard  Low Freq. Color: \_\_\_\_\_  
 Shock Limiters: \_\_\_\_\_  
 Camber Link: \_\_\_\_\_  
 Shock Locations: \_\_\_\_\_  
 Wing/Wickerbill: \_\_\_\_\_  
 Battery Position: \_\_\_\_\_  
 Notes: \_\_\_\_\_

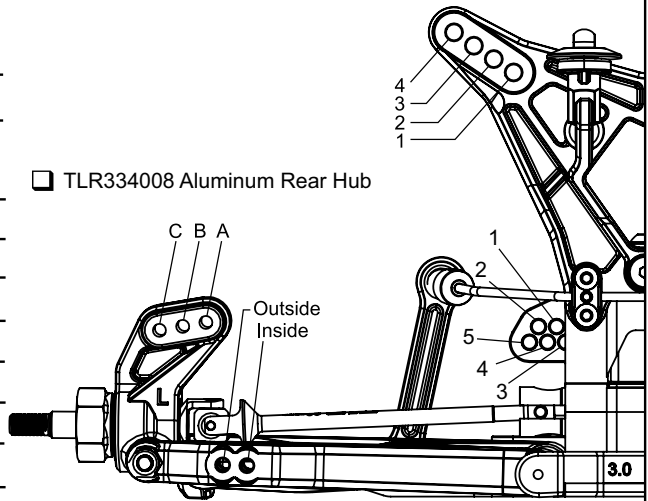

**Tires**

|         | Front | Rear  |
|---------|-------|-------|
| Tire:   | _____ | _____ |
| Insert: | _____ | _____ |
| Wheel:  | _____ | _____ |
| Notes:  | _____ |       |

**Electronics**

Radio: \_\_\_\_\_  
 Servo: \_\_\_\_\_  
 Motor: \_\_\_\_\_  
 Pinion: \_\_\_\_\_  
 Spur: \_\_\_\_\_  
 Battery: \_\_\_\_\_  
 Timing Advance: \_\_\_\_\_  
 Th/Brake EPA: \_\_\_\_\_  
 Th/Brake Expo: \_\_\_\_\_  
 Servo Expo: \_\_\_\_\_

**Team Orion R10 Setup**

Running Mode: \_\_\_\_\_  
 Drag Brake: \_\_\_\_\_  
 Voltage Protection: \_\_\_\_\_  
 DRRS Punch: \_\_\_\_\_  
 Brake Force: \_\_\_\_\_  
 Reverse Force: \_\_\_\_\_  
 Initial Brake: \_\_\_\_\_  
 Neutral Range: \_\_\_\_\_  
 Overheat Protection: \_\_\_\_\_  
 Boost Timing: \_\_\_\_\_  
 Turbo Timing: \_\_\_\_\_  
 Turbo Slope: \_\_\_\_\_  
 Turbo Delay: \_\_\_\_\_