

Name: _____ Date: _____ Event: _____
 City: _____ State: _____ Track: _____

Track Conditions: Indoor Outdoor Tight Open Smooth Rough Hard Packed Loose/Loamy Blue Groove Dry Wet Dusty Grass Astro Turf Low Bite Med Bite High Bite Other _____

Front Suspension

Toe: _____
 Ride Height: _____
 Camber: _____
 Caster: 10° 12° 15° 20°
 Sway Bar: _____
 Oil: _____
 Piston: _____
 Spring: Standard Low Freq. Color: _____
 Shock Limiters: _____
 Shock Location: _____
 Bump Steer Ball Stud: Standard Low Mount
 Bumper Steer Spacers: _____
 Camber Link: _____
 Ackermann: _____
 Notes: _____

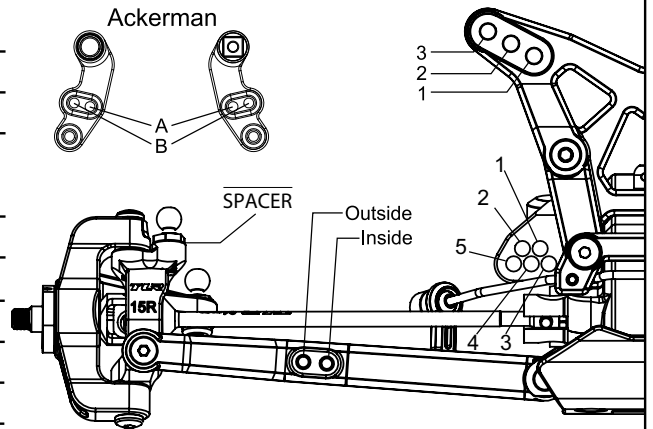

- TLR331012 Aluminum Servo Mount
- TLR334007 Aluminum Front Spindle
- TLR334009 Aluminum Steering Bellcrank

Rear Suspension

Toe: _____
 Anti-Squat: _____
 Roll Center: Low Roll Center (LRC) High Roll Center (HRC)
 Ride Height: _____
 Camber: _____
 Rear Hub Spacing: _____
 Hex Width: _____
 Sway Bar: _____
 Oil: _____
 Piston: _____
 Spring: Standard Low Freq. Color: _____
 Shock Limiters: _____
 Camber Link: _____
 Shock Locations: _____
 Wing/Wickerbill: _____
 Battery Position: _____
 Notes: _____

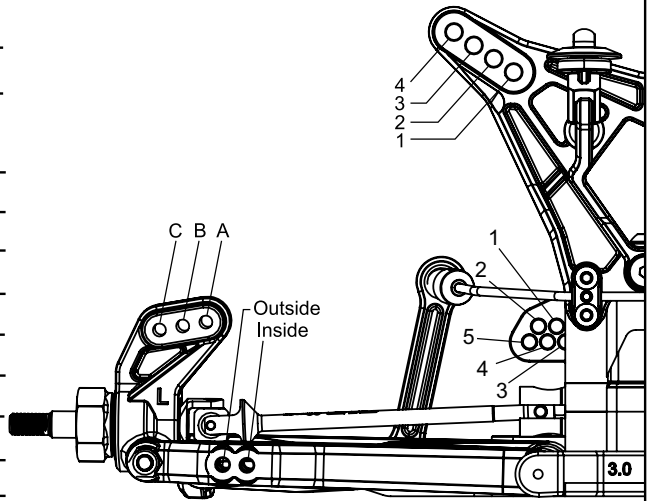

- TLR334008 Aluminum Rear Hub

Electronics

Radio: _____ Timing Advance: _____
 Servo: _____ Throttle/Brake Expo: _____
 ESC: _____ Servo Expo: _____
 Initial Brake: _____ Throttle/Brake EPA: _____
 Drag Brake: _____ Motor: _____
 Throttle Profile: _____ Pinion: _____ Spur: _____
 Battery: _____

Tires

	Compound	Insert	Additive
Front:	_____	_____	_____
Rear:	_____	_____	_____
Notes:	_____		