

Name: _____	Date: _____ Event: _____
City: _____ State: _____	Track: _____

Track Conditions:  Indoor  Outdoor  Tight  Open  Smooth  Rough  Hard Packed  Loose/Loamy  Blue Groove  Dry  Wet  Dusty  Grass  Astro Turf  Low Bite  Med Bite  High Bite  Other \_\_\_\_\_

**Front Suspension**

Toe: \_\_\_\_\_  
 Ride Height: \_\_\_\_\_  
 Camber: \_\_\_\_\_  
 Caster:  10°  12°  15°  20°  
 Sway Bar: \_\_\_\_\_  
 Oil: \_\_\_\_\_  
 Piston: \_\_\_\_\_  
 Spring:  Standard  Low Freq. Color: \_\_\_\_\_  
 Shock Limiters: \_\_\_\_\_  
 Shock Location: \_\_\_\_\_  
 Bump Steer Ball Stud:  Standard  Low Mount  
 Bumper Steer Spacers: \_\_\_\_\_  
 Camber Link: \_\_\_\_\_  
 Ackermann: \_\_\_\_\_  
 Notes: \_\_\_\_\_

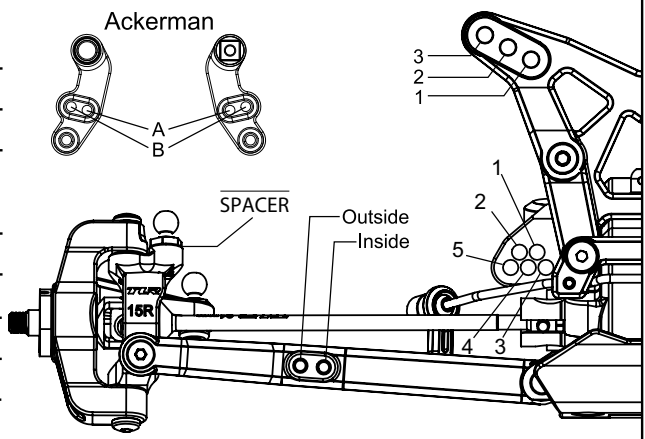

- TLR331012 Aluminum Servo Mount
- TLR334007 Aluminum Front Spindle
- TLR334009 Aluminum Steering Bellcrank

**Rear Suspension**

Toe: \_\_\_\_\_  
 Anti-Squat: \_\_\_\_\_  
 Roll Center:  Low Roll Center (LRC)  High Roll Center (HRC)  
 Ride Height: \_\_\_\_\_  
 Camber: \_\_\_\_\_  
 Rear Hub Spacing: \_\_\_\_\_  
 Hex Width: \_\_\_\_\_  
 Sway Bar: \_\_\_\_\_  
 Oil: \_\_\_\_\_  
 Piston: \_\_\_\_\_  
 Spring:  Standard  Low Freq. Color: \_\_\_\_\_  
 Shock Limiters: \_\_\_\_\_  
 Camber Link: \_\_\_\_\_  
 Shock Locations: \_\_\_\_\_  
 Wing/Wickerbill: \_\_\_\_\_  
 Battery Position: \_\_\_\_\_  
 Notes: \_\_\_\_\_

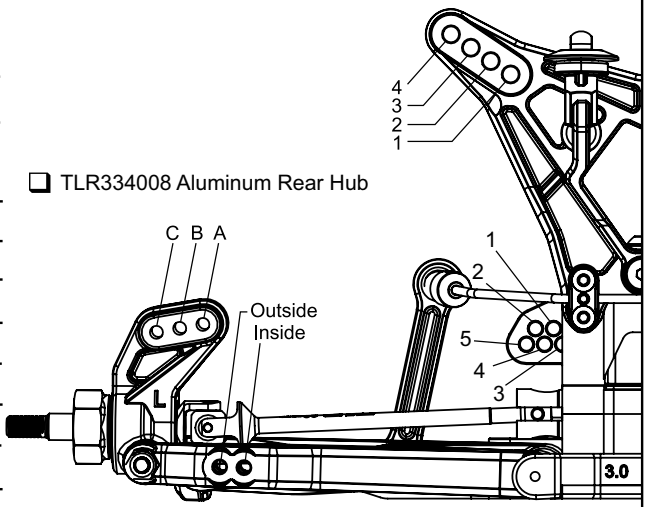

- TLR334008 Aluminum Rear Hub

**Tires**

	Front	Rear
Tire:	_____	_____
Insert:	_____	_____
Wheel:	_____	_____
Notes:	_____	

Electronics	Team Orion R10 Setup
Radio: _____	Running Mode: _____
Servo: _____	Drag Brake: _____
Motor: _____	Voltage Protection: _____
Pinion: _____	DRRS Punch: _____
Spur: _____	Brake Force: _____
Battery: _____	Reverse Force: _____
Timing Advance: _____	Initial Brake: _____
Th/Brake EPA: _____	Neutral Range: _____
Th/Brake Expo: _____	Overheat Protection: _____
Servo Expo: _____	Boost Timing: _____
	Turbo Timing: _____
	Turbo Slope: _____
	Turbo Delay: _____