

Name: _____		Date: _____		Event: _____	
City: _____		State: _____		Track: _____	
Track Conditions	<input type="checkbox"/> Indoor	<input type="checkbox"/> Tight	<input type="checkbox"/> Smooth	<input type="checkbox"/> Hard Packed	<input type="checkbox"/> Blue Groove
	<input type="checkbox"/> Outdoor	<input type="checkbox"/> Open	<input type="checkbox"/> Rough	<input type="checkbox"/> Loose/Loamy	<input type="checkbox"/> Dry
				<input type="checkbox"/> Wet	<input type="checkbox"/> Grass
				<input type="checkbox"/> Dusty	<input type="checkbox"/> Astro Turf
					<input type="checkbox"/> Low Bite
					<input type="checkbox"/> High Bite
					<input type="checkbox"/> Med Bite
					<input type="checkbox"/> Other _____

**Front Suspension**

Toe: \_\_\_\_\_

Ride Height: \_\_\_\_\_

Camber: \_\_\_\_\_

Caster:  10°  15°  20°

Sway Bar: \_\_\_\_\_

Oil: \_\_\_\_\_

Piston: \_\_\_\_\_

Spring:  Standard  Low Freq. Color: \_\_\_\_\_

Shock Limiters: \_\_\_\_\_

Shock Location: \_\_\_\_\_

Bump Steer Ball Stud:  Standard  Low Mount

Bumper Steer Spacers: \_\_\_\_\_

Camber Link: \_\_\_\_\_

Ackermann: \_\_\_\_\_

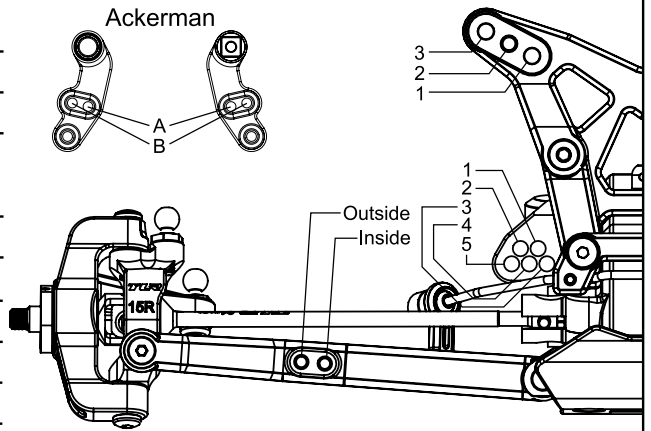

Notes: \_\_\_\_\_

\_\_\_\_\_

\_\_\_\_\_

**Rear Suspension**

Toe: \_\_\_\_\_

Anti-Squat: \_\_\_\_\_

Roll Center:  Low Roll Center (LRC)  High Roll Center (HRC)

Ride Height: \_\_\_\_\_

Camber: \_\_\_\_\_

Rear Hub Spacing: \_\_\_\_\_

Hex Width: \_\_\_\_\_

Sway Bar: \_\_\_\_\_

Oil: \_\_\_\_\_

Piston: \_\_\_\_\_

Spring:  Standard  Low Freq. Color: \_\_\_\_\_

Shock Limiters: \_\_\_\_\_

Camber Link: \_\_\_\_\_

Shock Locations: \_\_\_\_\_

Wing/Wickerbill: \_\_\_\_\_

Battery Position: \_\_\_\_\_

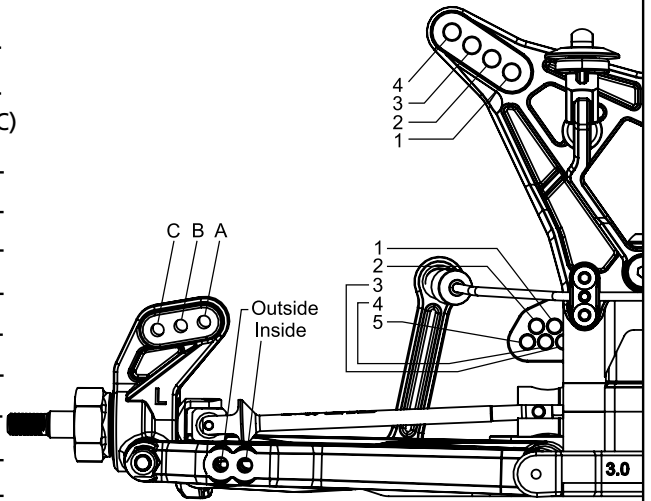

**Electronics**

Radio: \_\_\_\_\_

Servo: \_\_\_\_\_

ESC: \_\_\_\_\_

Initial Brake: \_\_\_\_\_

Drag Brake: \_\_\_\_\_

Throttle Profile: \_\_\_\_\_

Timing Advance: \_\_\_\_\_

Throttle/Brake Expo: \_\_\_\_\_

Servo Expo: \_\_\_\_\_

Throttle/Brake EPA: \_\_\_\_\_

Motor: \_\_\_\_\_

Pinion: \_\_\_\_\_ Spur: \_\_\_\_\_

Battery: \_\_\_\_\_

Tires	Compound	Insert	Additive
Front: _____	_____	_____	_____
Rear: _____	_____	_____	_____
Notes: _____			