

Name: _____		Date: _____		Event: _____	
City: _____		State: _____		Track: _____	
Track Conditions	<input type="checkbox"/> Indoor	<input type="checkbox"/> Tight	<input type="checkbox"/> Smooth	<input type="checkbox"/> Hard Packed	<input type="checkbox"/> Blue Groove
	<input type="checkbox"/> Outdoor	<input type="checkbox"/> Open	<input type="checkbox"/> Rough	<input type="checkbox"/> Loose/Loamy	<input type="checkbox"/> Dry
			<input type="checkbox"/> Wet	<input type="checkbox"/> Grass	<input type="checkbox"/> Low Bite
			<input type="checkbox"/> Dusty	<input type="checkbox"/> Astro Turf	<input type="checkbox"/> Med Bite
					<input type="checkbox"/> High Bite
					<input type="checkbox"/> Other _____

FRONT SUSPENSION

Toe: _____

Ride Height: _____

Camber: _____

Caster: 10° 12° 15° 20°

Sway Bar: _____

Oil: _____

Piston: _____

Spring: Standard Low Freq. Color: _____

Shock Limiters: _____

Shock Location: _____

Bump Steer Ball Stud: Standard Low Mount

Bumper Steer Spacers: _____

Camber Link: _____

Ackermann: _____

Notes: _____

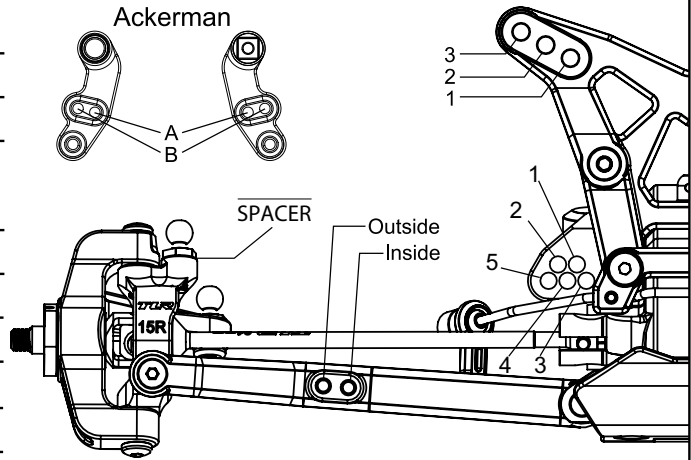

- TLR331012 Aluminum Servo Mount
- TLR334007 Aluminum Front Spindle
- TLR334009 Aluminum Steering Bellcrank
- TLR234045 Front Pivot Brace, Steel

REAR SUSPENSION

Toe: _____

Anti-Squat: _____

Roll Center: Low Roll Center (LRC) High Roll Center (HRC)

Ride Height: _____

Camber: _____

Rear Hub Spacing: _____

Hex Width: _____

Sway Bar: _____

Oil: _____

Piston: _____

Spring: Standard Low Freq. Color: _____

Shock Limiters: _____

Camber Link: _____

Shock Locations: _____

Wing/Wickerbill: _____

Battery Position: _____

Notes: _____

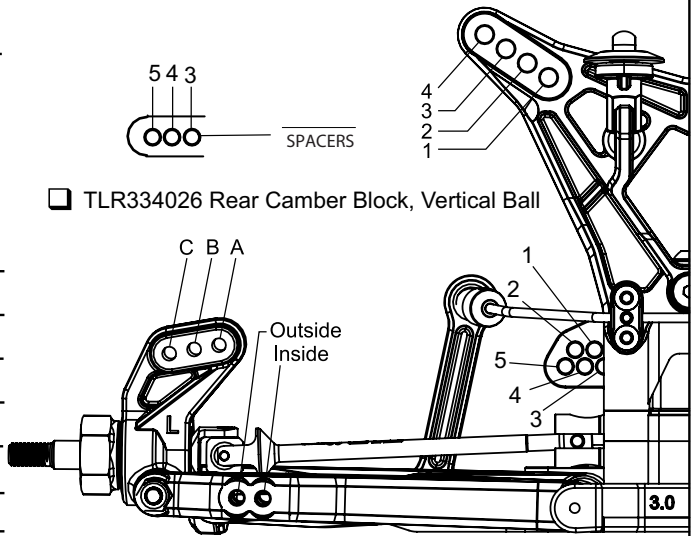

- TLR334026 Rear Camber Block, Vertical Ball
- TLR334008 Aluminum Rear Hub

ELECTRONICS

Timing Advance: _____

Radio: _____ Throttle/Brake Expo: _____

Servo: _____ Servo Expo: _____

ESC: _____ Throttle/Brake EPA: _____

Initial Brake: _____ Motor: _____

Drag Brake: _____ Pinion: _____ Spur: _____

Throttle Profile: _____ Battery: _____

TIRES

	Compound	Insert	Additive
Front: _____			
Rear: _____			
Notes: _____			