

| | | | | | |
|------------------|----------------------------------|--------------------------------|---------------------------------|--------------------------------------|--------------------------------------|
| Name: _____ | | Date: _____ | | Event: _____ | |
| City: _____ | | State: _____ | | Track: _____ | |
| Track Conditions | <input type="checkbox"/> Indoor | <input type="checkbox"/> Tight | <input type="checkbox"/> Smooth | <input type="checkbox"/> Hard Packed | <input type="checkbox"/> Blue Groove |
| | <input type="checkbox"/> Outdoor | <input type="checkbox"/> Open | <input type="checkbox"/> Rough | <input type="checkbox"/> Loose/Loamy | <input type="checkbox"/> Dry |
| | | | | <input type="checkbox"/> Wet | <input type="checkbox"/> Grass |
| | | | | <input type="checkbox"/> Dusty | <input type="checkbox"/> Astro Turf |
| | | | | | <input type="checkbox"/> Low Bite |
| | | | | | <input type="checkbox"/> High Bite |
| | | | | | <input type="checkbox"/> Med Bite |
| | | | | | <input type="checkbox"/> Other _____ |

FRONT SUSPENSION

Toe: _____

Ride Height: _____

Camber: _____

Caster: 10° 12.5° 15° 20°

Diff. Type: Ball Gear Setting/Oil: _____

Driveshaft Type: CVA Universal

Front Drive: Full-Time 4WD Clicker: _____

Sway Bar: None White Yellow Pink

Oil: _____

Piston: _____

Spring: Standard Low Freq. Color: _____

Shock Limiters: _____ Stroke: _____

Shock Location: _____

Bump Steer Ball Stud: Standard Low Mount

Bumper Steer Spacers: _____

Camber Link: _____

Ackermann: A B Adjustable: _____

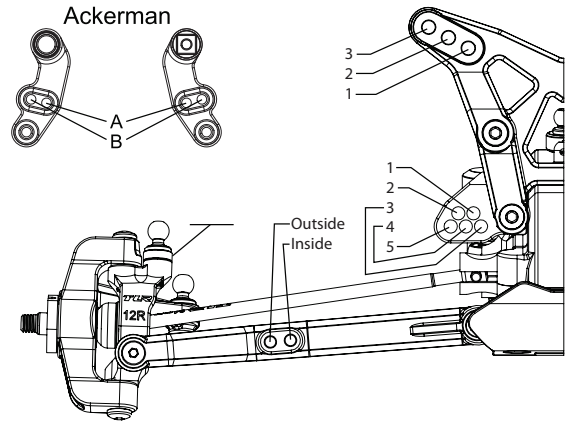

Notes: _____

REAR SUSPENSION

Toe: 2.0° 2.5° 3.0°

Anti-Squat: 1° 2° 2.5° 3°

Roll Center: Low Roll Center (LRC) High Roll Center (HRC)

Ride Height: _____

Camber: _____

Diff. Type: Ball Gear Setting/Oil: _____

Driveshaft Type: CVA Universal

Rear Hub Spacing: _____

Hex Width: _____

Sway Bar: None White Yellow Pink

Oil: _____

Piston: _____

Spring: Standard Low Freq. Color: _____

Shock Limiters: _____ Stroke: _____

Camber Link: _____

Shock Locations: _____

Wing/Wickerbill: _____

Battery Type: Shorty Saddles

Battery Position: _____

Rear Suspension: 22 Hub/Hex 22-4 Hub/Hex

Rear Shock Orientation: Front of Arm Rear of Arm

ELECTRONICS

Radio: _____

Servo: _____

ESC: _____

Initial Brake: _____

Drag Brake: _____

Throttle Profile: _____

Timing Advance: _____

Throttle/Brake Expo: _____

Servo Expo: _____

Throttle/Brake EPA: _____

Motor: _____

Pinion: _____ Spur: _____

Battery: _____

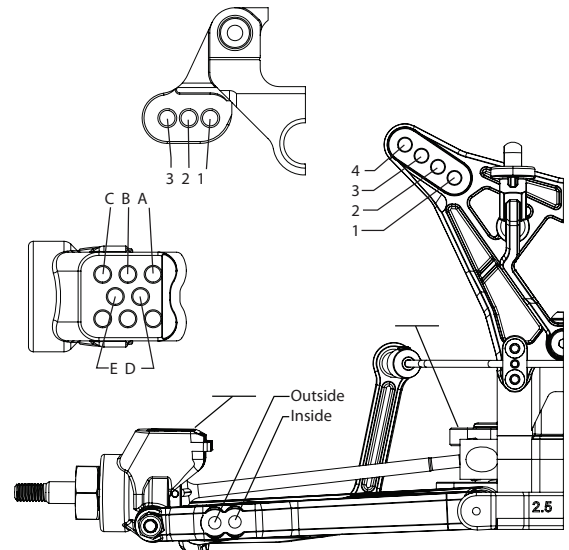

Notes: _____

| TIRES | Compound | Insert | Additive | NOTES |
|--------------|----------|--------|----------|-------|
| Front: _____ | | | | |
| Rear: _____ | | | | |